

### ■ Dimensions

**Note:** All units are in millimeters unless otherwise indicated.

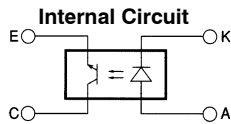
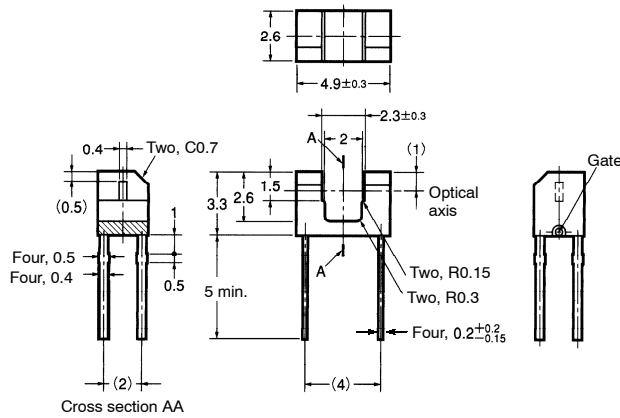

Terminal No.	Name
A	Anode
K	Cathode
C	Collector
E	Emitter

Unless otherwise specified, the tolerances are  $\pm 0.2$  mm.

### ■ Features

- Ultra-compact with a sensor width of 4.9 mm and a slot width of 2 mm.
- Low-height of 3.3 mm.
- PCB mounting type.
- High resolution with a 0.4-mm-wide aperture.

### ■ Absolute Maximum Ratings ( $T_a = 25^\circ\text{C}$ )

Item		Symbol	Rated value
Emitter	Forward current	$I_F$	50 mA (see note 1)
	Pulse forward current	$I_{FP}$	---
	Reverse voltage	$V_R$	5 V
Detector	Collector-Emitter voltage	$V_{CEO}$	30 V
	Emitter-Collector voltage	$V_{ECO}$	4.5 V
	Collector current	$I_C$	30 mA
	Collector dissipation	$P_C$	80 mW (see note 1)
	Ambient temperature	Operating	$T_{opr}$
	Storage	$T_{stg}$	$-30^\circ\text{C}$ to $85^\circ\text{C}$
Soldering temperature		$T_{sol}$	$260^\circ\text{C}$ (see note 2)

- Note:**
1. Refer to the temperature rating chart if the ambient temperature exceeds  $25^\circ\text{C}$ .
  2. Complete soldering within 3 seconds.

### ■ Ordering Information

Description	Part number
Photomicrosensor (Transmissive)	EE-SX1105

### ■ Electrical and Optical Characteristics ( $T_a = 25^\circ\text{C}$ )

Item		Symbol	Value	Condition
Emitter	Forward voltage	$V_F$	1.3 V typ., 1.6 V max.	$I_F = 50$ mA
	Reverse current	$I_R$	10 $\mu\text{A}$ max.	$V_R = 5$ V
	Peak emission wavelength	$\lambda_P$	950 nm typ.	$I_F = 50$ mA
Detector	Light current	$I_L$	0.2 mA min.	$I_F = 20$ mA, $V_{CE} = 5$ V
	Dark current	$I_D$	500 nA max.	$V_{CE} = 10$ V, 0 lx
	Leakage current	$I_{LEAK}$	---	---
	Collector-Emitter saturated voltage	$V_{CE(sat)}$	0.4 V max.	$I_F = 20$ mA, $I_L = 0.1$ mA
	Peak spectral sensitivity wavelength	$\lambda_P$	800 nm typ.	$V_{CE} = 5$ V
Rising time		$t_r$	10 $\mu\text{s}$ typ.	$V_{CC} = 5$ V, $R_L = 100$ $\Omega$ , $I_F = 20$ mA
Falling time		$t_f$	10 $\mu\text{s}$ typ.	$V_{CC} = 5$ V, $R_L = 100$ $\Omega$ , $I_F = 20$ mA

Engineering Data

Forward Current vs. Collector Dissipation Temperature Rating

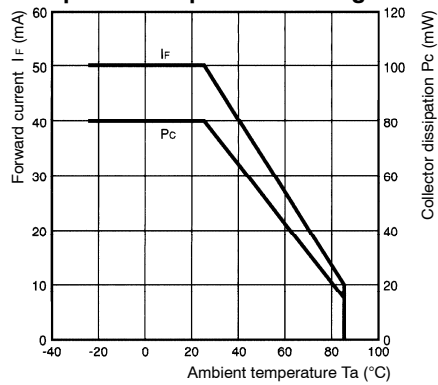

Forward Current vs. Forward Voltage Characteristics (Typical)

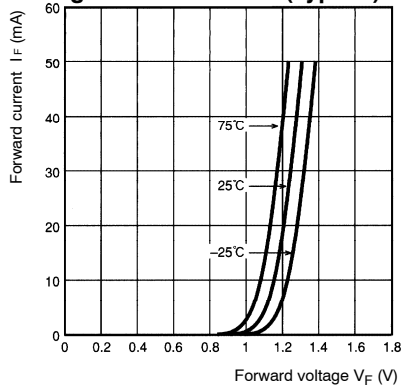

Light Current vs. Forward Current Characteristics (Typical)

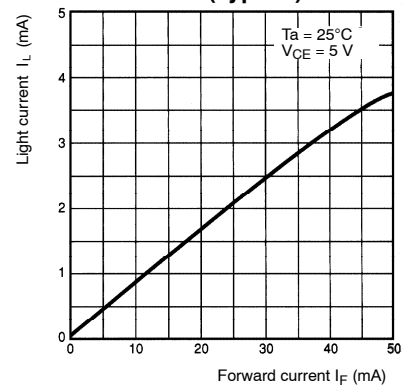

Light Current vs. Collector-Emitter Voltage Characteristics (Typical)

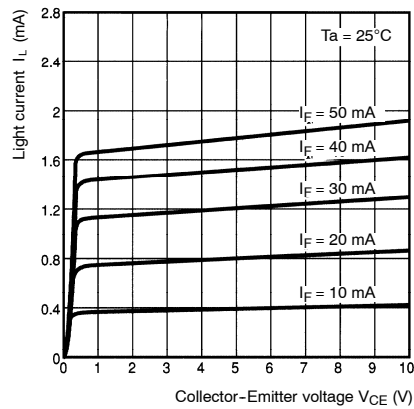

Relative Light Current vs. Ambient Temperature Characteristics (Typical)

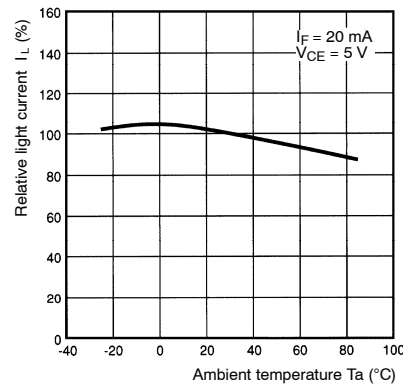

Dark Current vs. Ambient Temperature Characteristics (Typical)

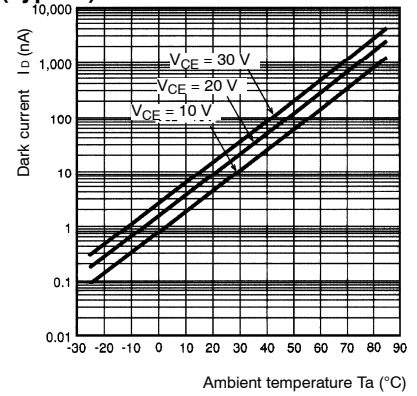

Response Time vs. Light Current Characteristics (Typical)

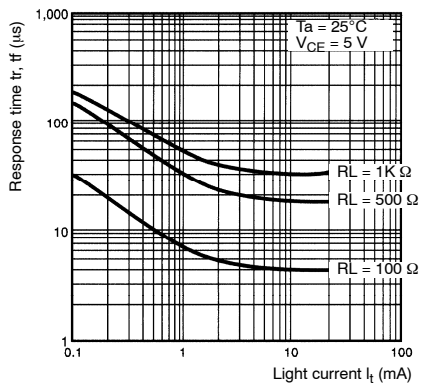

Sensing Position Characteristics (Typical)

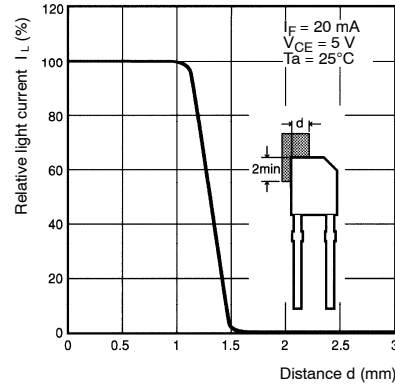

Sensing Position Characteristics (Typical)

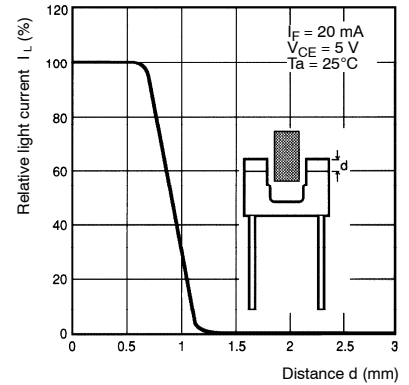

Response Time Measurement Circuit

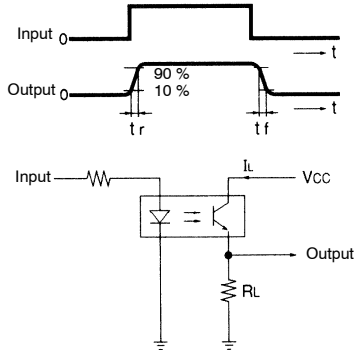

**NOTE: DIMENSIONS SHOWN ARE IN MILLIMETERS. To convert millimeters to inches divide by 25.4.**

---

**OMRON**<sup>®</sup>

**OMRON ELECTRONICS LLC**

One East Commerce Drive  
Schaumburg, IL 60173

**847-882-2288**

**OMRON CANADA, INC.**

885 Milner Avenue  
Toronto, Ontario M1B 5V8

**416-286-6465**

**OMRON ON-LINE**

Global – <http://www.omron.com>  
USA – <http://www.omron.com/oei>  
Canada – <http://www.omron.com/oci>