

NE570/571 – Compandor

GENERAL DESCRIPTION

The 570/571 is a versatile low cost dual gain control circuit in which either channel may be used as a dynamic range compressor or expander. Each channel has a full wave rectifier to detect the average value of the signal; a linearized, temperature compensated variable gain cell; and an operational amplifier.

The 570/571 is well suited for use in telephone subscriber and trunk carrier systems, communications systems and hi-fi audio systems.

FEATURES

- Complete compressor and expander in 1 IC
- Temperature compensated
- Greater than 110dB dynamic range
- Operates down to 6Vdc
- System levels adjustable with external components
- Distortion may be trimmed out

CIRCUIT DESCRIPTION

The 570/571 compandor building blocks, as shown in the block diagram are a full wave rectifier, a variable gain cell, an operational amplifier and a bias system. The arrangement of these blocks in the IC result in a circuit which can perform well with few external components, yet can be adapted to many diverse applications.

The full wave rectifier rectifies the input current which flows from the rectifier input, to an internal summing node which is biased at V_{REF} . The rectified current is averaged on an external filter capacitor tied to the C_{RECT} terminal, and the average value of the input current controls the gain of the variable gain cell. The gain will thus be proportional to the average value of the input signal for capacitively coupled voltage inputs as shown in the following equation. Note that for capacitively coupled inputs there is no offset voltage capable of producing a gain error. The only error will come from bias current of the rectifier (supplied internally) which is less than $1\mu A$.

$$G \propto \frac{|V_{IN} - V_{REF}|_{ave}}{R_1} \quad \text{or}$$

$$G \propto \frac{|V_{IN}|_{ave}}{R_1}$$

The speed with which gain changes to follow changes in input signal levels is determined by the rectifier filter capacitor. A small capacitor will yield rapid response but will not fully filter low frequency signals. Any ripple on the gain control signal will modulate the signal passing through the variable gain cell. In an expander or compressor application, this would lead to third harmonic distortion, so there is a tradeoff to be made between fast attack and decay times, and distortion. For step changes in amplitude, the change in gain with time is shown by this equation.

$$G(t) = (G_{initial} - G_{final}) e^{-t/\tau} + G_{final}; \quad \tau = 10K \times C_{RECT}$$

The variable gain cell is a current in, current out device with the ratio I_{OUT}/I_{IN} controlled by the rectifier. I_{IN} is the current which flows from the ΔG input to an internal summing node biased at V_{REF} . The following equation applies for capacitively coupled inputs. The output current, I_{OUT} , is fed to the summing node of the op amp.

$$I_{IN} = \frac{V_{IN} - V_{REF}}{R_2} = \frac{V_{IN}}{R_2}$$

A compensation scheme built into the ΔG cell compensates for temperature, and cancels out odd harmonic distortion. The only distortion which remains is even harmonics, and they exist only because of internal offset voltages. The THD trim terminal provides a means for nulling the internal offsets for low distortion operation.

The operational amplifier (which is internally compensated) has the non-inverting input tied to V_{REF} , and the inverting input connected to the ΔG cell output as well as brought out externally. A resistor, R_3 , is brought out from the summing node and allows compressor or expander gain to be determined only by internal components. The output stage is capable of $\pm 20mA$ output current. This allows a +13dBm (3.5V rms) output into a 300 Ω load which, with a series resistor and proper transformer, can result in +13dBm with a 600 Ω output impedance.

PLEASE QUOTE STOCK NO.
AND MANUFACTURERS PART NO. WHEN ORDERING

III GEMINI

Signetics

Integrated Circuits — Compandor

NE50/571 Cont.

DC ELECTRICAL CHARACTERISTICS $T_A = 25^\circ\text{C}$, $V_{CC} = 15\text{V}^1$

PARAMETER	TEST CONDITIONS	NE570			NE571			UNIT
		Min	Typ	Max	Min	Typ	Max	
V_{CC} Supply voltage	No Signal	6		24	6		18	V
Supply current			3.2		4.0			mA
Output current capability		± 20						mA
Output slew rate			± 5					V/us
Gain cell distortion ²	Untrimmed		.3	1.0		.5	2.0	%
	Trimmed		.05			.1		
Resistor tolerance			± 5	± 15				%
Internal reference voltage		1.7	1.8	1.9	1.65	1.8	1.95	V
Output dc shift ³	Untrimmed		± 20	± 50		± 30	± 100	mV
Expander output noise	No signal, 20Hz–20kHz		20					μV
			-15					dBRNC
Unity gain level		-1	0	+1	-1.5	0	+1.5	dB
Gain change ^{2, 4}	$-40^\circ\text{C} < T < 70^\circ\text{C}$		± 1	± 3		± 1	± 5	dB
	$0^\circ\text{C} < T < 70^\circ\text{C}$		± 1	± 2		± 1	± 4	
Reference drift ⁴	$-40^\circ\text{C} < T < 70^\circ\text{C}$		+2, -25	-10, -40		+2, -25	+20, -50	mV
	$0^\circ\text{C} < T < 70^\circ\text{C}$		± 5	± 10		± 5	± 20	
Resistor drift ⁴	$-40^\circ\text{C} < T < 70^\circ\text{C}$		+8, -0					%
	$0^\circ\text{C} < T < 70^\circ\text{C}$		+1, -0					
Tracking error ⁵	Rectifier input=							dB
	+6dBm		± 2					
	-10dBm		+2	-2, +4		+2	-2, +5	
	-20dBm		+2	-3, +6		+2	-4, +7	
	-30dBm		+2	-5, +1		+2	-1, +1.5	
	-40dBm		+2, -4			+2, -4		

NOTES

1. Except where indicated, the 571 specifications are identical to the 570
2. Measured at 0dBm
3. Expander ac input change from no signal to 0dBm
4. Relative to value at $T_A = 25^\circ\text{C}$
5. Relative to 0dBm

PLEASE QUOTE STOCK NO.
AND MANUFACTURERS PART NO. WHEN ORDERING



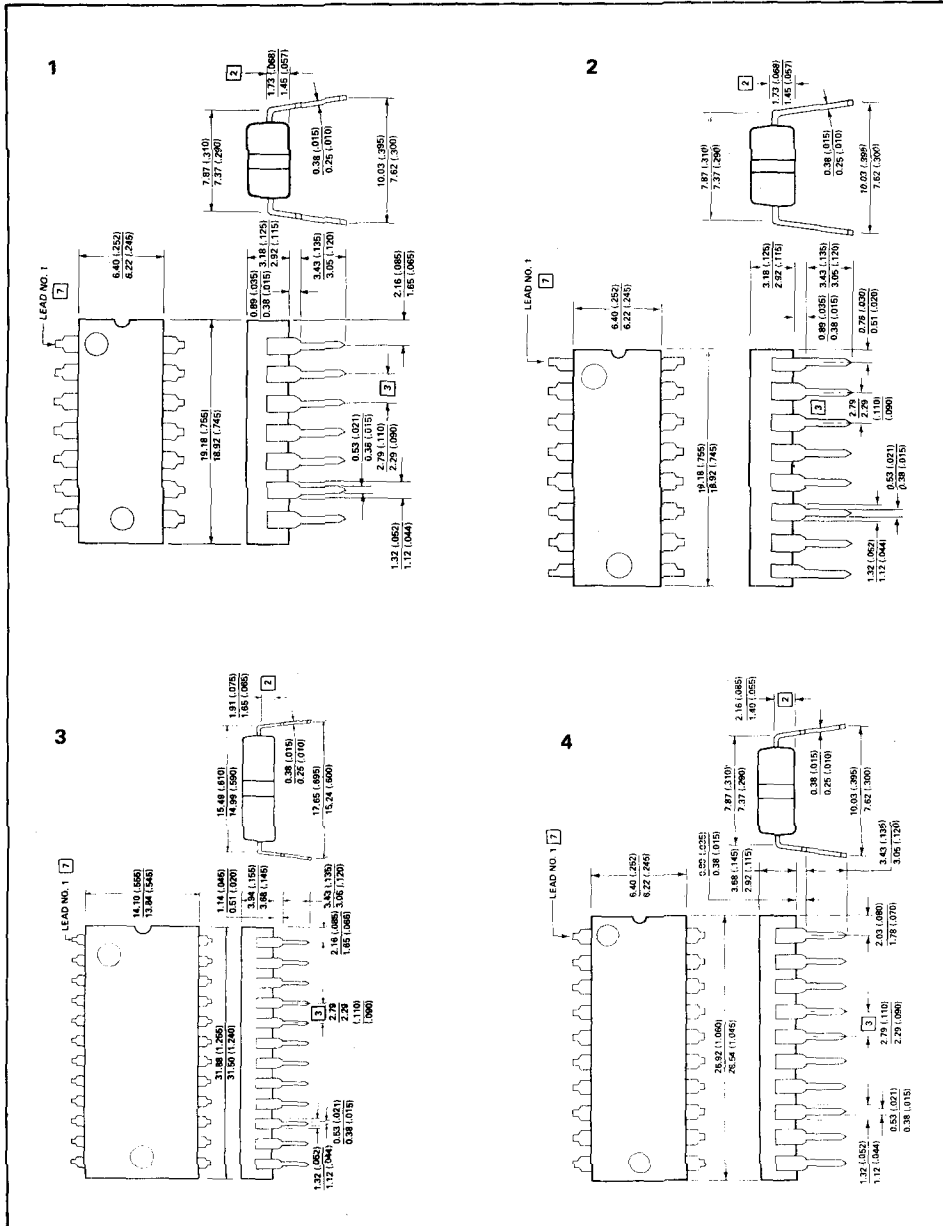

PLEASE QUOTE STOCK NO.
AND MANUFACTURERS PART NO. WHEN ORDERING



Signetics

Outline Drawings

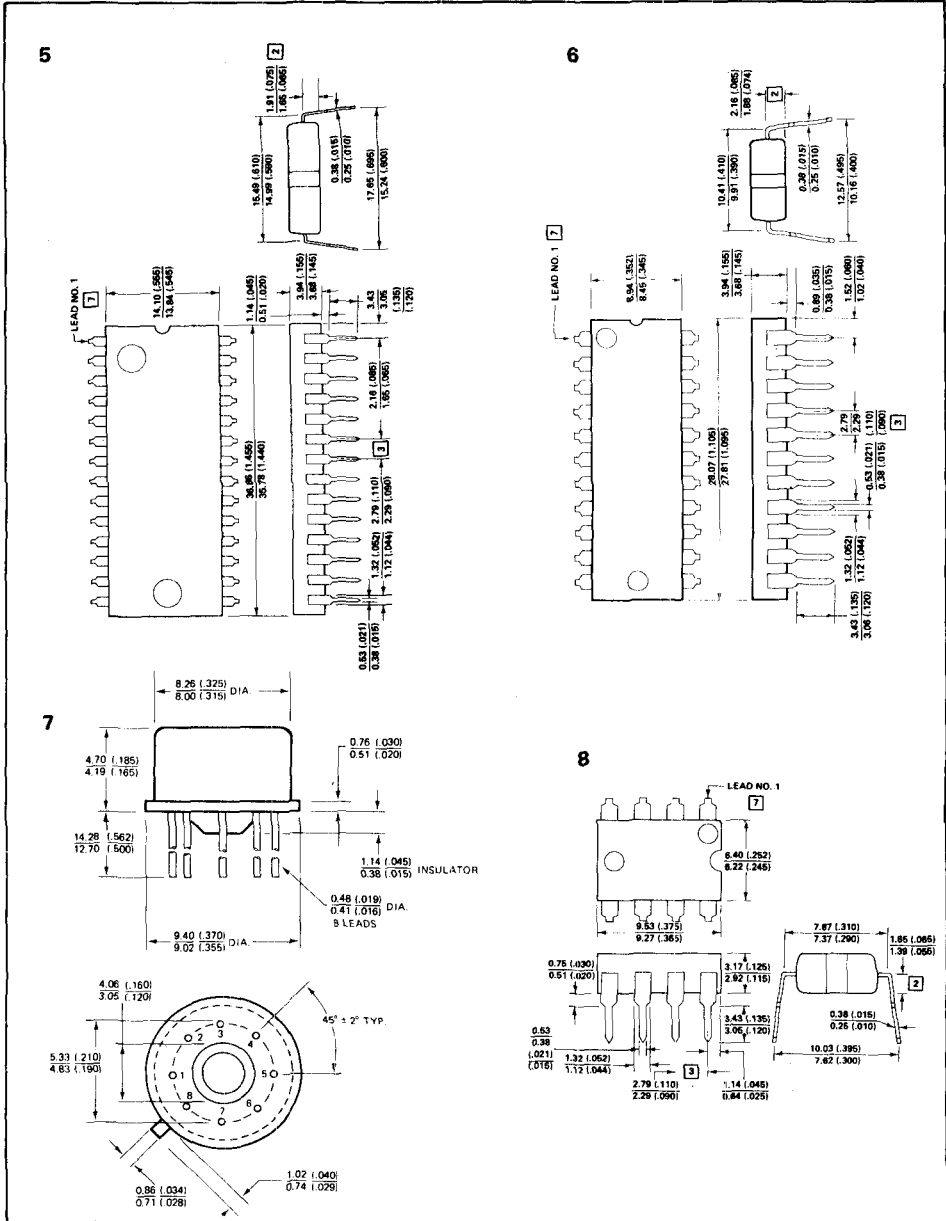

GEMINI

FOR CURRENT PRICES PHONE
HARLOW (0279) 29644

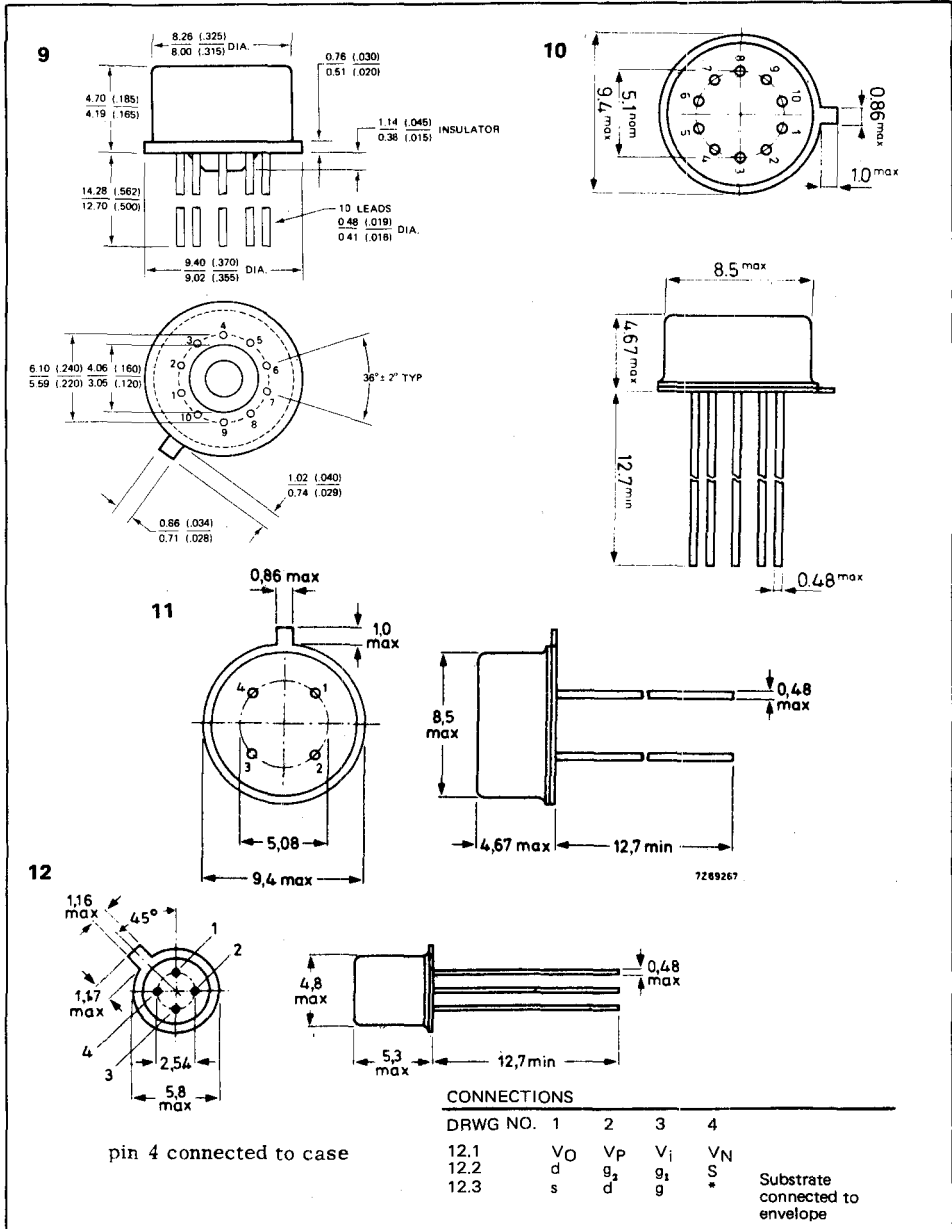

PLEASE QUOTE STOCK NO.
AND MANUFACTURERS PART NO. WHEN ORDERING

ITT GEMINI

Signetics

Outline Drawings

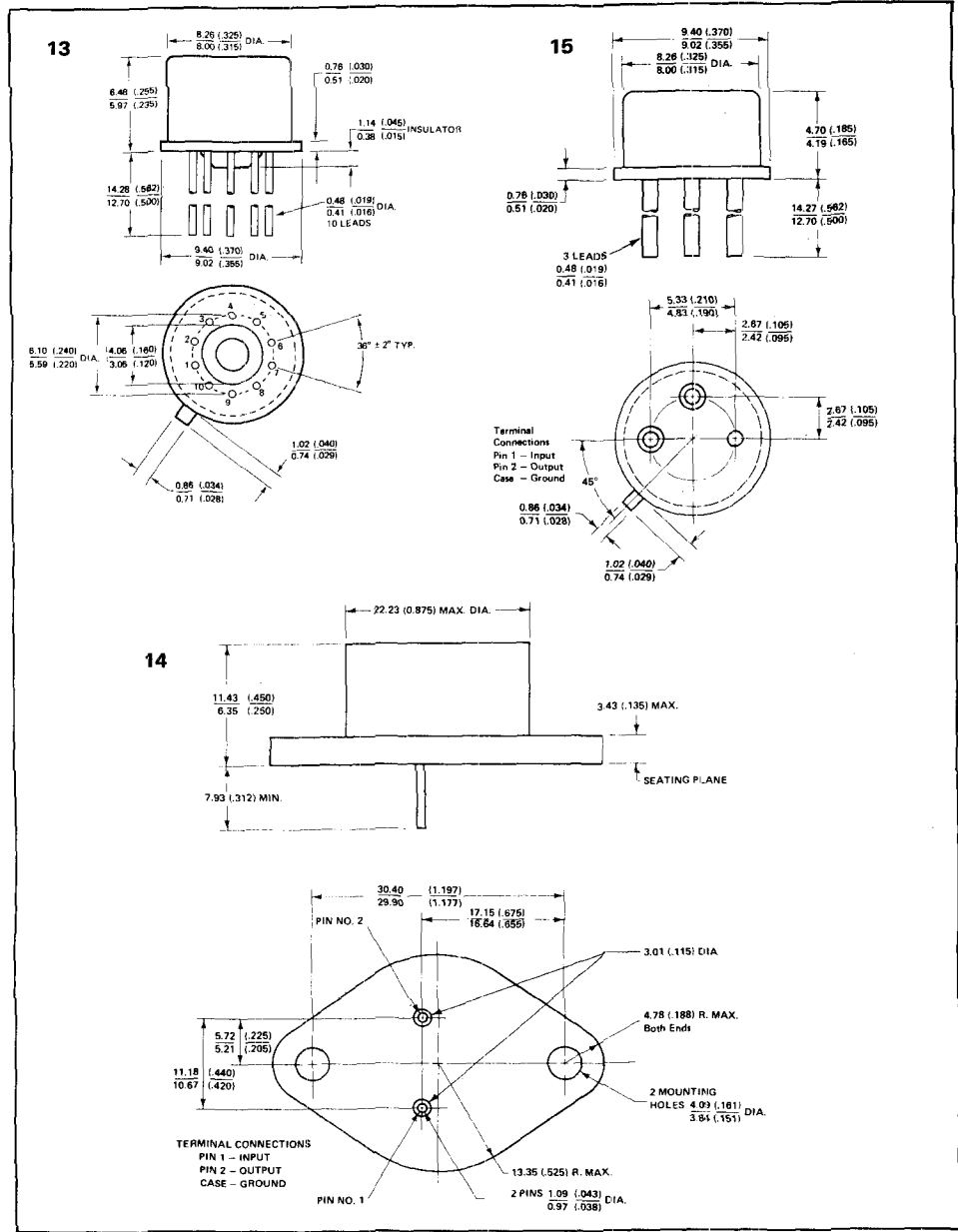

FOR CURRENT PRICES PHONE HARLOW (0279) 29644

16

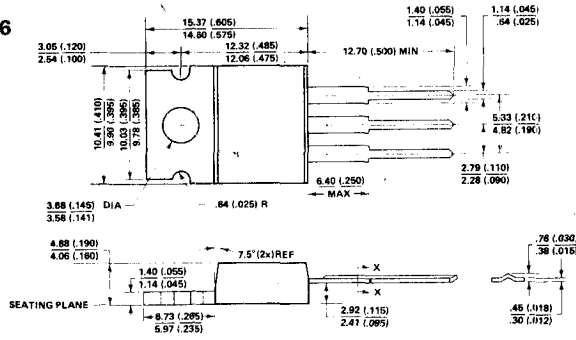

17

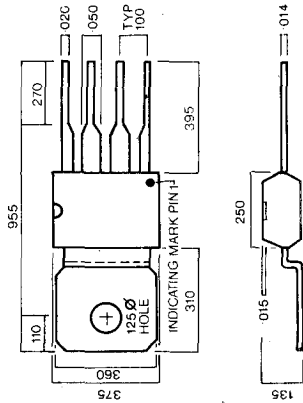

19

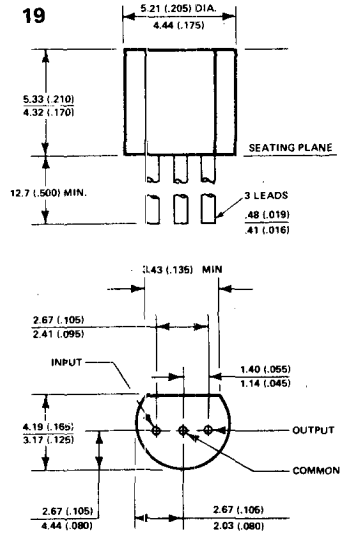

PLEASE QUOTE STOCK NO.
AND MANUFACTURER'S PART NO. WHEN ORDERING

TTT GEMINI

Signetics

Outline Drawings

