

FOD3184

3A Output Current, High Speed MOSFET/IGBT Gate Driver Optocoupler

Features

- High noise immunity characterized by 35kV/μs common mode rejection
- Guaranteed operating temperature range of -40°C to +100°C
- 3A minimum peak output current for medium power MOSFET/IGBT
- Fast switching speed
 - 210ns max. propagation delay
 - 65ns max pulse width distortion
- Fast output rise/fall time
 - Offers lower dynamic power dissipation
- 250kHz maximum switching speed
- Wide V_{CC} operating range from 15V to 30V
- Use of P-Channel MOSFETs at output stage enables output voltage swing close to the supply rail (rail-to-rail output)
- Under voltage lockout protection (UVLO) with hysteresis – optimized for driving IGBTs
- Safety and regulatory approvals
 - UL1577, 3,750 VAC_{RMS} for 1 min.
 - IEC60747-5-2, 1,414 peak working insulation voltage (pending approval)
 - Minimum creepage distance of 8.0mm
 - Minimum clearance distance of 8.0mm (Option T)
 - Minimum insulation thickness of 0.5mm

Applications

- Plasma Display Panel
- High performance DC/DC convertor
- High performance switch mode power supply
- High performance uninterruptible power supply
- Isolated Power MOSFET/IGBT gate drive

Description

The FOD3184 is a 3A Output Current, High Speed MOSFET/IGBT Gate Drive Optocoupler. It consists of a aluminium gallium arsenide (AlGaAs) light emitting diode optically coupled to a CMOS detector with PMOS and NMOS output power transistors integrated circuit power stage. It is ideally suited for high frequency driving of power MOSFETs/IGBT used in Plasma Display Panels (PDPs), motor control inverter applications and high performance DC/DC converters.

The device is packaged in an 8-pin dual in-line housing compatible with 260°C reflow processes for lead free solder compliance.

Functional Block Diagram

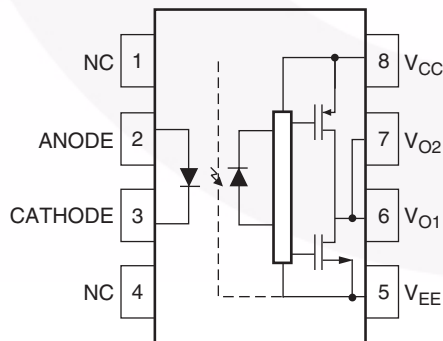

Note:

A 0.1μF bypass capacitor must be connected between pins 5 and 8.

Package Outlines

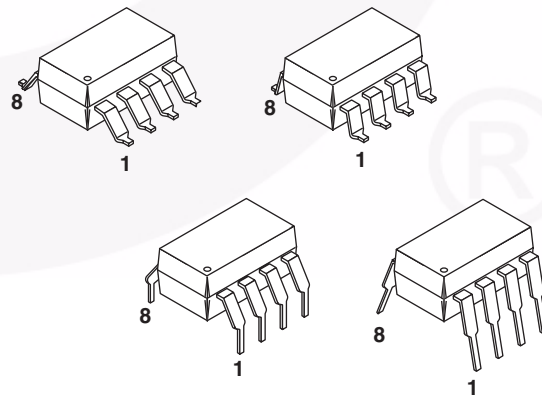

Truth Table

LED	$V_{CC}-V_{EE}$ "Positive Going" (Turn-on)	$V_{CC}-V_{EE}$ "Negative Going" (Turn-off)	V_O
Off	0V to 30V	0V to 30V	Low
On	0V to 11.5V	0V to 10V	Low
On	11.5V to 13.5V	10V to 12V	Transition
On	13.5V to 30V	12V to 30V	High

Pin Definitions

Pin #	Name	Description
1	NC	Not Connected
2	Anode	LED Anode
3	Cathode	LED Cathode
4	NC	Not Connected
5	V_{EE}	Negative Supply Voltage
6	V_{O2}	Output Voltage 2 (internally connected to V_{O1})
7	V_{O1}	Output Voltage 1
8	V_{CC}	Positive Supply Voltage

Safety and Insulation Ratings

As per IEC 60747-5-2. This optocoupler is suitable for “safe electrical insulation” only within the safety limit data. Compliance with the safety ratings shall be ensured by means of protective circuits.

Symbol	Parameter	Min.	Typ.	Max.	Unit
	Installation Classifications per DIN VDE 0110/1.89 Table 1				
	For Rated Mains Voltage < 150Vrms		I-IV		
	For Rated Mains Voltage < 300Vrms		I-IV		
	For Rated Mains Voltage < 450Vrms		I-III		
	For Rated Mains Voltage < 600Vrms		I-III		
	For Rated Mains Voltage < 1000Vrms (Option T, TS)		I-III		
	Climatic Classification		40/100/21		
	Pollution Degree (DIN VDE 0110/1.89)		2		
CTI	Comparative Tracking Index	175			
V _{PR}	Input to Output Test Voltage, Method b, V _{IORM} × 1.875 = V _{PR} , 100% Production Test with t _m = 1 sec., Partial Discharge < 5pC	2651			
	Input to Output Test Voltage, Method a, V _{IORM} × 1.5 = V _{PR} , Type and Sample Test with t _m = 60 sec., Partial Discharge < 5 pC	2121			
V _{IORM}	Max Working Insulation Voltage	1,414			V _{peak}
V _{IOTM}	Highest Allowable Over Voltage	6000			V _{peak}
	External Creepage	8			mm
	External Clearance	7.4			mm
	External Clearance (for Option T or TS - 0.4" Lead Spacing)	10.16			mm
	Insulation Thickness	0.5			mm
	Safety Limit Values – Maximum Values Allowed in the Event of a Failure				
T _{Case}	Case Temperature	150			°C
I _{S,INPUT}	Input Current	25			mA
P _{S,OUTPUT}	Output Power	250			mW
R _{IO}	Insulation Resistance at T _S , V _{IO} = 500V	10 ⁹			Ω

Absolute Maximum Ratings ($T_A = 25^\circ\text{C}$ unless otherwise specified)

Stresses exceeding the absolute maximum ratings may damage the device. The device may not function or be operable above the recommended operating conditions and stressing the parts to these levels is not recommended. In addition, extended exposure to stresses above the recommended operating conditions may affect device reliability. The absolute maximum ratings are stress ratings only.

Symbol	Parameter	Value	Units
T_{STG}	Storage Temperature	-40 to +125	$^\circ\text{C}$
T_{OPR}	Operating Temperature	-40 to +100	$^\circ\text{C}$
T_J	Junction Temperature	-40 to +125	$^\circ\text{C}$
T_{SOL}	Lead Solder Temperature – Wave solder (Refer to Reflow Temperature Profile, pg. 13)	260 for 10 sec.	$^\circ\text{C}$
$I_{F(AVG)}$	Average Input Current ⁽¹⁾	25	mA
$I_{F(tr, tf)}$	LED Current Minimum Rate of Rise/Fall	250	ns
$I_{F(TRAN)}$	Peak Transient Input Current (<1 μs pulse width, 300pps)	1.0	A
V_R	Reverse Input Voltage	5	V
$I_{OH(PEAK)}$	“High” Peak Output Current ⁽²⁾	3	A
$I_{OL(PEAK)}$	“Low” Peak Output Current ⁽²⁾	3	A
$V_{CC} - V_{EE}$	Supply Voltage	-0.5 to 35	V
$V_{O(PEAK)}$	Output Voltage	0 to V_{CC}	V
P_O	Output Power Dissipation ⁽³⁾	250	mW
P_D	Total Power Dissipation ⁽³⁾	295	mW

Recommended Operating Conditions

The Recommended Operating Conditions table defines the conditions for actual device operation. Recommended operating conditions are specified to ensure optimal performance to the datasheet specifications. Fairchild does not recommend exceeding them or designing to absolute maximum ratings.

Symbol	Parameter	Value	Units
$V_{CC} - V_{EE}$	Power Supply	15 to 30	V
$I_{F(ON)}$	Input Current (ON)	10 to 16	mA
$V_{F(OFF)}$	Input Voltage (OFF)	-3.0 to 0.8	V

Electrical-Optical Characteristics (DC)

Apply over all recommended conditions, typical value is measured at $V_{CC} = 30V$, $V_{EE} = 0V$, $T_A = 25^\circ C$, unless otherwise specified.

Symbol	Parameter	Test Conditions	Min.	Typ.*	Max.	Unit
I_{OH}	High Level Output Current	$V_{OH} = (V_{CC} - V_{EE} - 1V)$		0.9	-0.5	A
		$V_{OH} = (V_{CC} - V_{EE} - 6V)$			-2.5	
I_{OL}	Low Level Output Current	$V_{OL} = (V_{CC} - V_{EE} + 1V)$	0.5	1		A
		$V_{OL} = (V_{CC} - V_{EE} + 6V)$	2.5			
V_{OH}	High Level Output Voltage ⁽⁴⁾⁽⁵⁾	$I_O = -100mA, I_F = 10mA$	$V_{CC} - 0.5$			V
		$I_O = -2.5A, I_F = 10mA$	$V_{CC} - 7$			
V_{OL}	Low Level Output Voltage ⁽⁴⁾⁽⁵⁾	$I_O = 100mA, I_F = 0mA$			$V_{EE} + 0.5$	V
		$I_O = 2.5A, I_F = 0mA$			$V_{EE} + 7$	
I_{CCH}	High Level Supply Current	Output Open, $I_F = 10$ to $16mA$		2.6	3.3	mA
I_{CCL}	Low Level Supply Current	Output Open, $V_F = -3.0$ to $0.8V$		2.5	3.3	mA
I_{FLH}	Threshold Input Current Low to High	$I_O = 0mA, V_O > 5V$		3.0	7.5	mA
V_{FHL}	Threshold Input Voltage High to Low	$I_O = 0mA, V_O < 5V$	0.8			V
V_F	Input Forward Voltage	$I_F = 10mA$	1.1	1.43	1.8	V
$\Delta V_F / T_A$	Temperature Coefficient of Forward Voltage	$I_F = 10mA$		-1.5		mV/°C
V_{UVLO+}	UVLO Threshold	$V_O > 5V, I_F = 10mA$	11.5	13.0	13.5	V
V_{UVLO-}		$V_O < 5V, I_F = 10mA$	10.0	11.5	12.0	V
$UVLO_{HYST}$	UVLO Hysteresis			1.5		V
BV_R	Input Reverse Breakdown Voltage	$I_R = 10\mu A$	5			V
C_{IN}	Input Capacitance	$f = 1MHz, V_F = 0V$		25		pF

*Typical values at $T_A = 25^\circ C$

Switching Characteristics

Apply over all recommended conditions, typical value is measured at $V_{CC} = 30V$, $V_{EE} = 0V$, $T_A = 25^\circ C$, unless otherwise specified.

Symbol	Parameter	Test Conditions	Min.	Typ.*	Max.	Unit
t_{PLH}	Propagation Delay Time to High Output Level ⁽⁶⁾	$I_F = 10mA$, $R_g = 10\Omega$, $f = 250kHz$, Duty Cycle = 50%, $C_g = 10nF$	50	120	210	ns
t_{PHL}	Propagation Delay Time to Low Output Level ⁽⁶⁾		50	145	210	ns
P_{WD}	Pulse Width Distortion ⁽⁷⁾		35	65	ns	
P_{DD} ($t_{PHL} - t_{PLH}$)	Propagation Delay Difference Between Any Two Parts ⁽⁸⁾		-90	90	ns	
t_r	Rise Time	$C_L = 10nF$, $R_g = 10\Omega$		27		ns
t_f	Fall Time			20		ns
$t_{UVLO\ ON}$	UVLO Turn On Delay			2.0		μs
$t_{UVLO\ OFF}$	UVLO Turn Off Delay			0.3		μs
$ CM_H $	Output High Level Common Mode Transient Immunity ^{(9) (10)}	$T_A = +25^\circ C$, $I_f = 10mA$ to $16mA$, $V_{CM} = 2kV$, $V_{CC} = 30V$	35	50		kV/ μs
$ CM_L $	Output Low Level Common Mode Transient Immunity ^{(9) (11)}	$T_A = +25^\circ C$, $V_f = 0V$, $V_{CM} = 2kV$, $V_{CC} = 30V$	35	50		kV/ μs

*Typical values at $T_A = 25^\circ C$

Isolation Characteristics

Symbol	Parameter	Test Conditions	Min.	Typ.*	Max.	Unit
V_{ISO}	Withstand Isolation Voltage ^{(12) (13)}	$T_A = 25^\circ C$, R.H. < 50%, $t = 1min.$, $I_{I-O} \leq 10\mu A$	5000			V_{rms}
R_{I-O}	Resistance (input to output) ⁽¹³⁾	$V_{I-O} = 500V$		10^{11}		Ω
C_{I-O}	Capacitance (input to output)	Freq. = 1MHz		1		pF

*Typical values at $T_A = 25^\circ C$

Notes:

1. Derate linearly above TD°C free air temperature at a rate of TBDmA/°C.
2. Maximum pulse width = 10μs.
3. Derate linearly above TBD°C, free air temperature at the rate of TBDmW/°C.
4. In this test, V_{OH} is measured with a dc load current of 100mA. When driving capacitive load V_{OH} will approach V_{CC} as I_{OH} approaches zero amps.
5. Maximum pulse width = 1ms, maximum duty cycle = 20%.
6. t_{PHL} propagation delay is measured from the 50% level on the falling edge of the input pulse to the 50% level of the falling edge of the V_O signal. t_{PLH} propagation delay is measured from the 50% level on the rising edge of the input pulse to the 50% level of the rising edge of the V_O signal.
7. PWD is defined as | t_{PHL} - t_{PLH} | for any given device.
8. The difference between t_{PHL} and t_{PLH} between any two FOD3184 parts under same test conditions.
9. Pin 1 and 4 need to be connected to LED common.
10. Common mode transient immunity in the high state is the maximum tolerable dV_{CM}/dt of the common mode pulse V_{CM} to assure that the output will remain in the high state (i.e. V_O > 15V).
11. Common mode transient immunity in a low state is the maximum tolerable dV_{CM}/dt of the common mode pulse, V_{CM}, to assure that the output will remain in a low state (i.e. V_O < 1.0V).
12. In accordance with UL 1577, each optocoupler is proof tested by applying an insulation test voltage > 6000Vrms, 60Hz for 1 second (leakage detection current limit I_{L0} < 10μA).
13. Device considered a two-terminal device: pins on input side shorted together and pins on output side shorted together.

Typical Performance Curves

Fig. 1 Input Forward Current vs. Forward Voltage

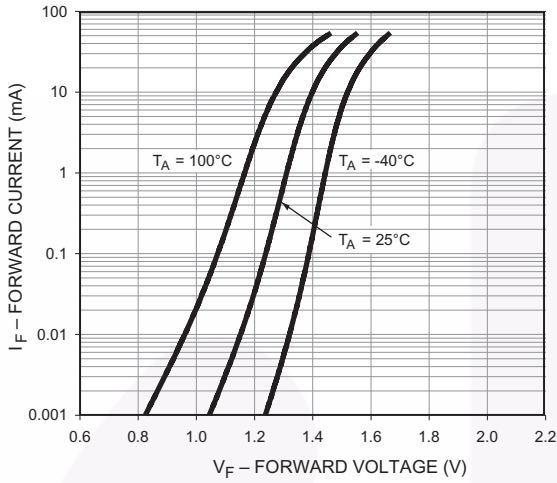

Fig. 2 Low To High Input Current Threshold vs. Ambient Temperature

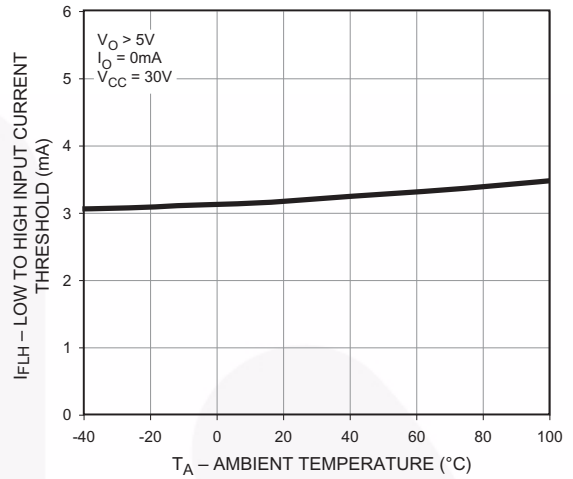

Fig. 3 Output Low Voltage vs. Ambient Temperature

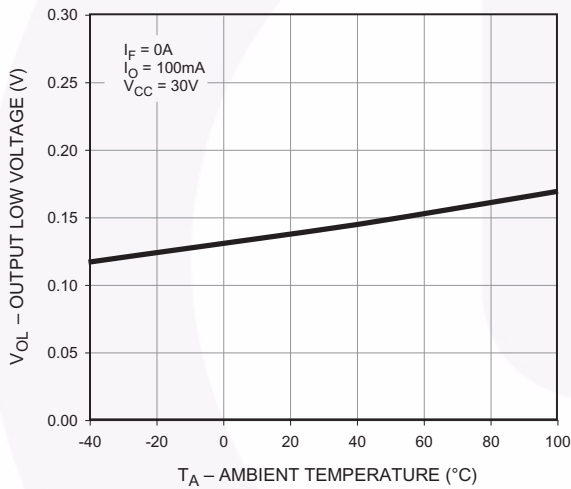

Fig. 4 High Output Voltage Drop vs. Ambient Temperature

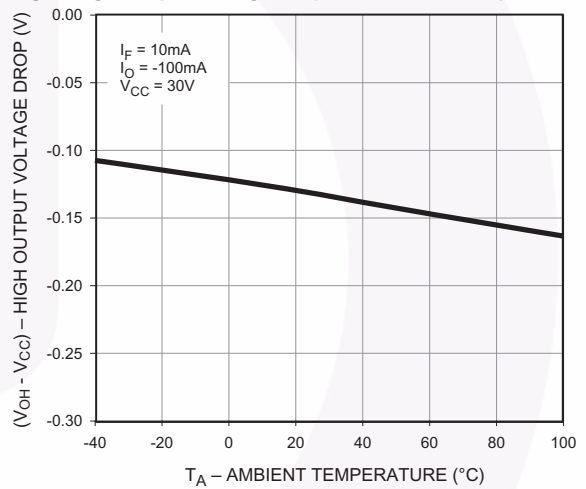

Fig. 5 Supply Current vs. Ambient Temperature

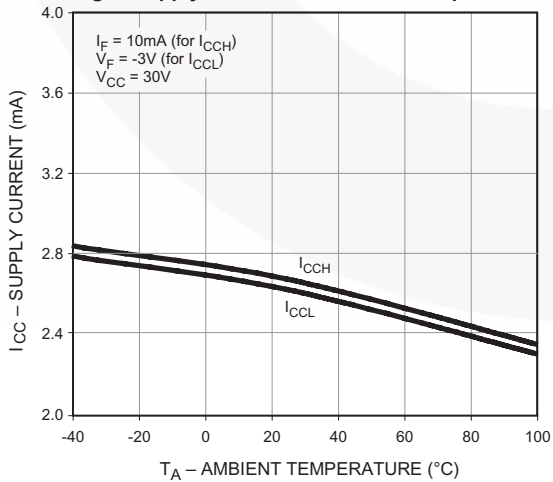
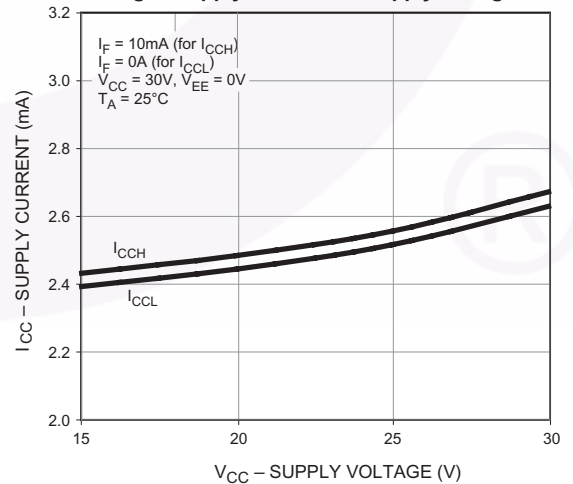
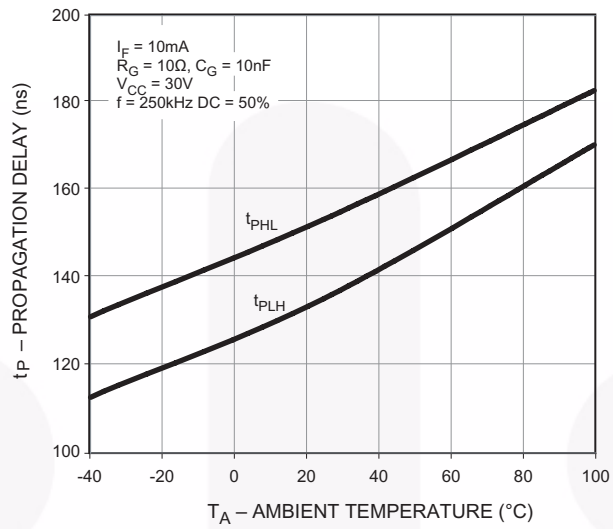

Fig. 6 Supply Current vs. Supply Voltage



Typical Performance Curves (Continued)

Fig. 7 Propagation Delay vs. Ambient Temperature



Test Circuit

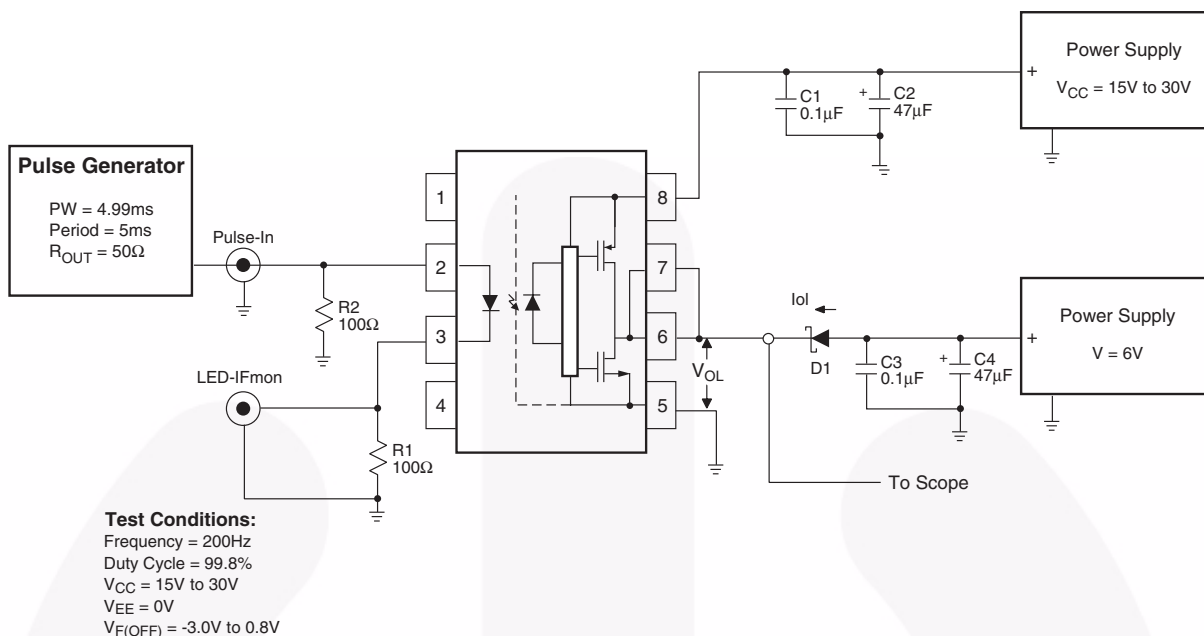

Figure 8. I_{OL} Test Circuit

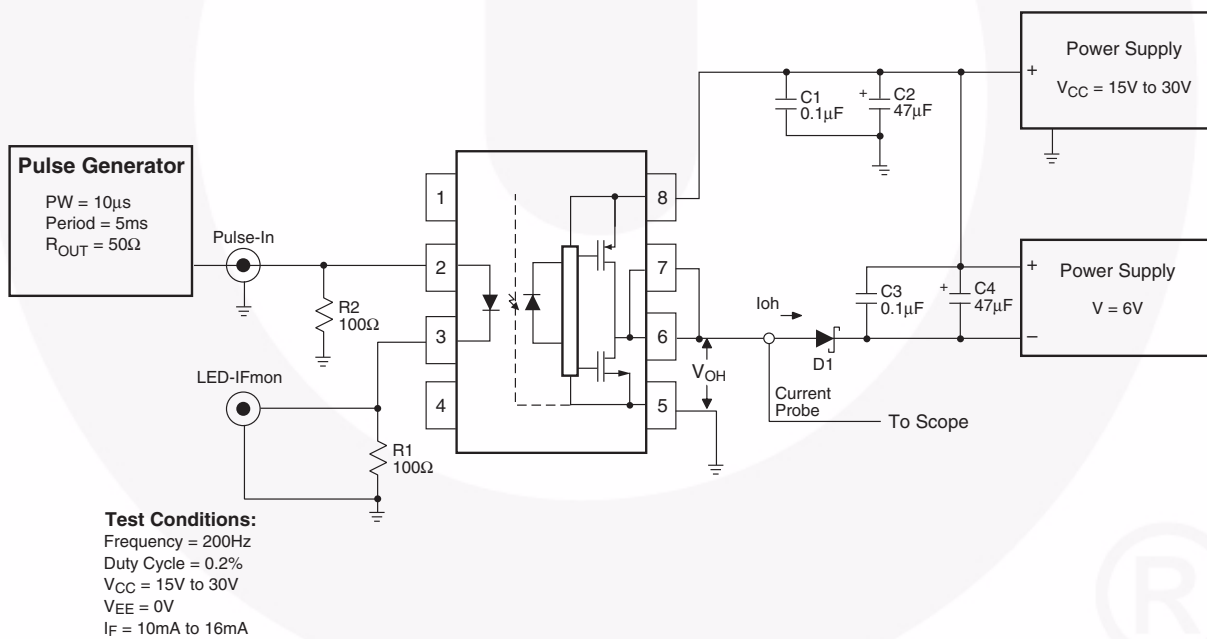

Figure 9. I_{OH} Test Circuit

Test Circuit (Continued)

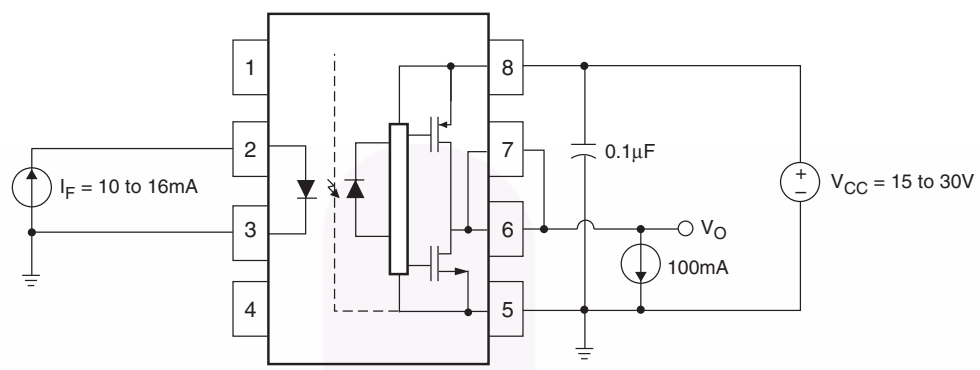

Figure 10. V_{OH} Test Circuit

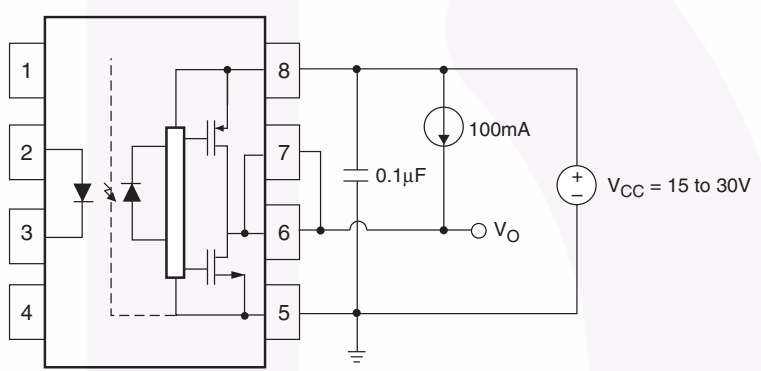

Figure 11. V_{OL} Test Circuit



Test Circuit (Continued)

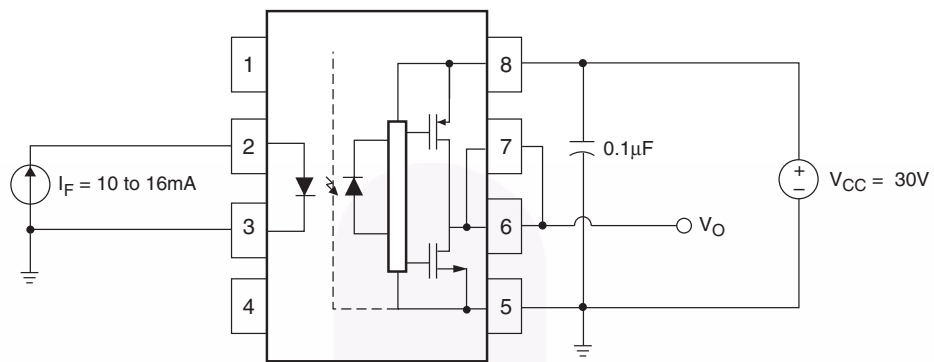

Figure 12. I_{CCH} Test Circuit

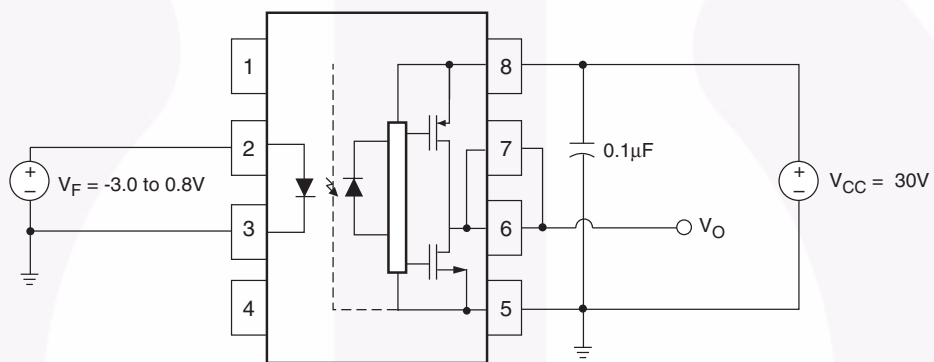

Figure 13. I_{CCL} Test Circuit



Test Circuit (Continued)

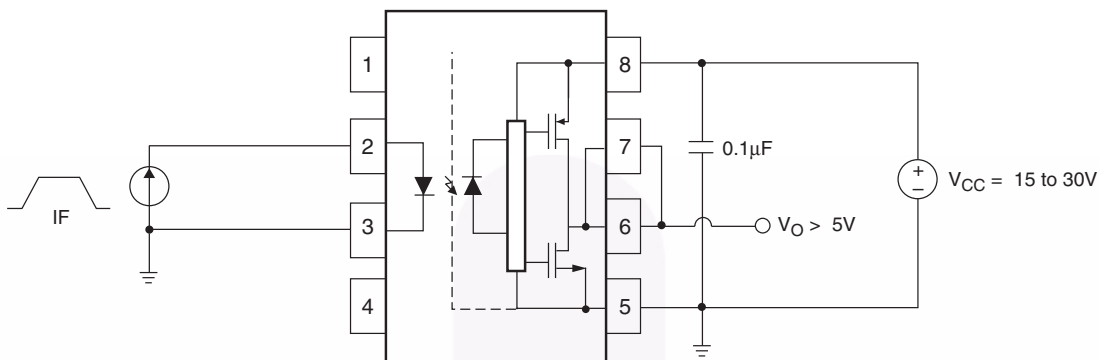

Figure 14. I_{FLH} Test Circuit

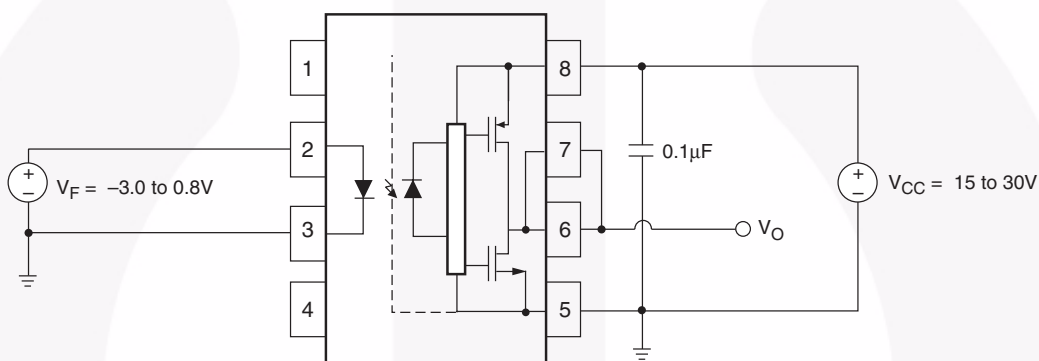

Figure 15. V_{FHL} Test Circuit

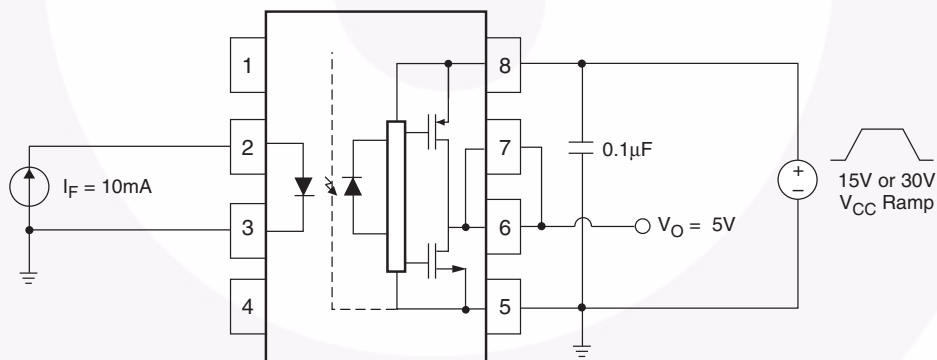

Figure 16. UVLO Test Circuit

Test Circuit (Continued)

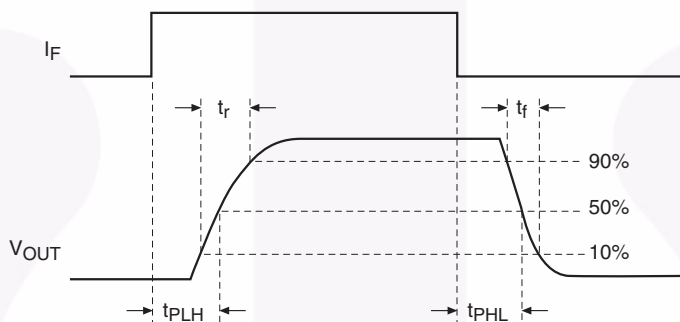
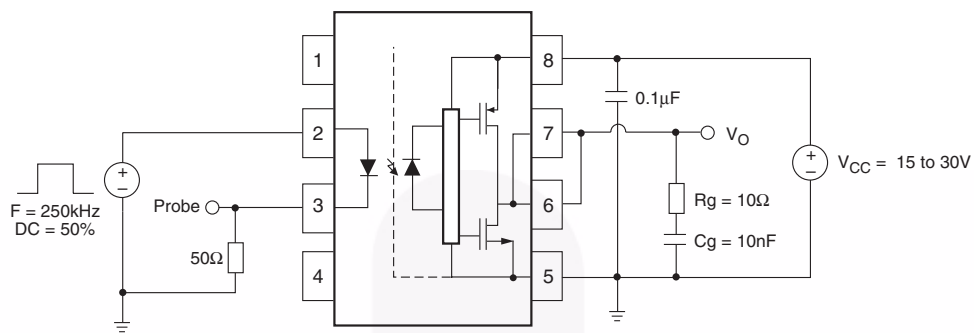

Figure 17. t_{PHL} , t_{PLH} , t_R and t_F Test Circuit and Waveforms

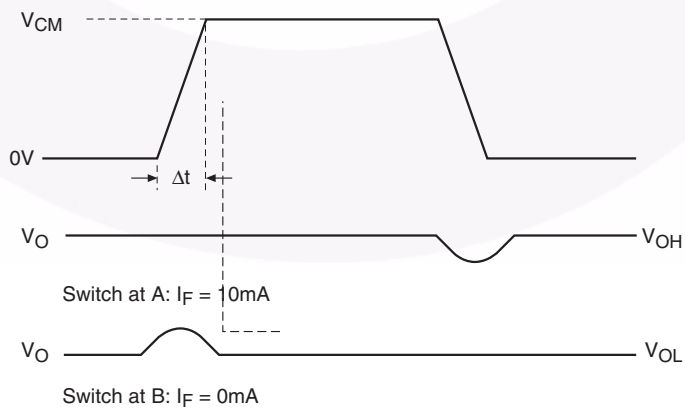
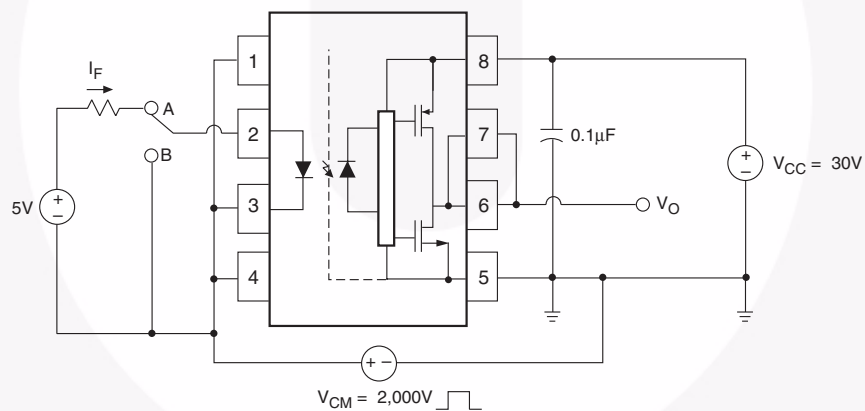
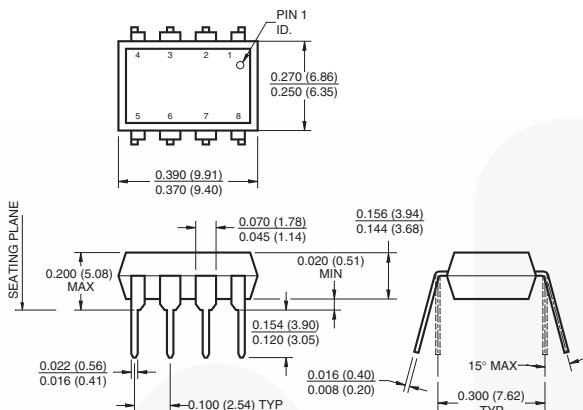

Figure 18. CMR Test Circuit and Waveforms

Package Dimensions

Through Hole



0.4" Lead Spacing (Option T)

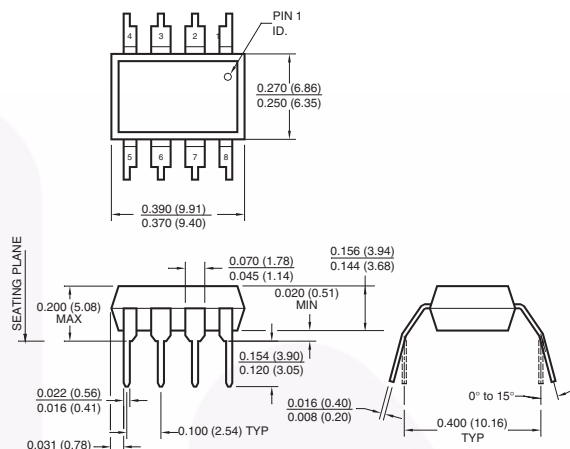

Surface Mount – 0.3" Lead Spacing (Option S)

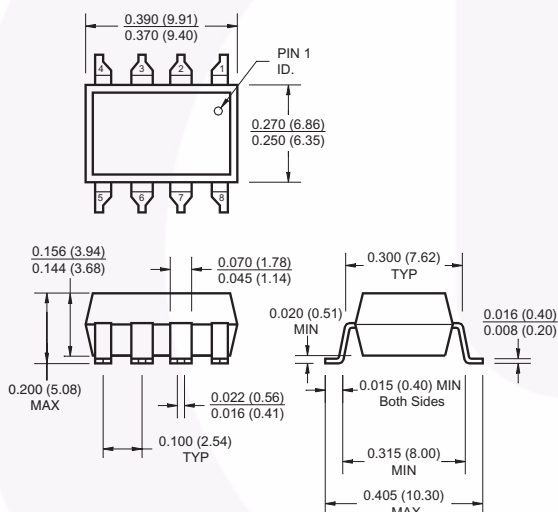

8-Pin Surface Mount DIP – Land Pattern (Option S)

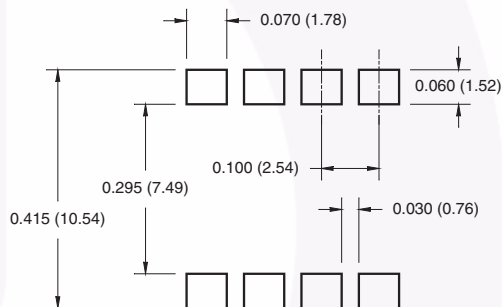

Note:

All dimensions are in inches (millimeters)

Package drawings are provided as a service to customers considering Fairchild components. Drawings may change in any manner without notice. Please note the revision and/or date on the drawing and contact a Fairchild Semiconductor representative to verify or obtain the most recent revision. Package specifications do not expand the terms of Fairchild's worldwide terms and conditions, specifically the warranty therein, which covers Fairchild products.

Always visit Fairchild Semiconductor's online packaging area for the most recent package drawings:
<http://www.fairchildsemi.com/packaging/>

Package Dimensions (Continued)

Surface Mount – 0.4" Lead Spacing (Option TS)

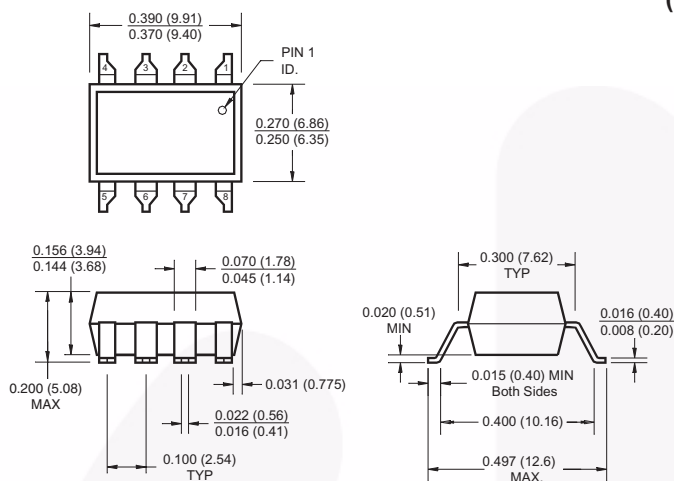

8-Pin Surface Mount DIP – Land Pattern (Option TS)

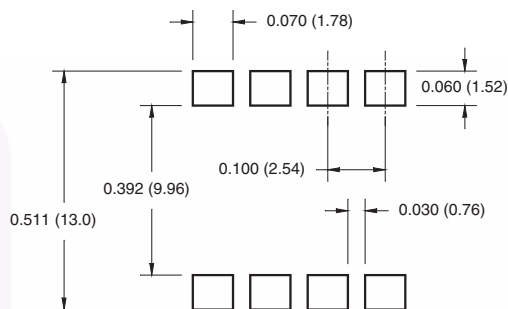

Note:

All dimensions are in inches (millimeters)

Package drawings are provided as a service to customers considering Fairchild components. Drawings may change in any manner without notice. Please note the revision and/or date on the drawing and contact a Fairchild Semiconductor representative to verify or obtain the most recent revision. Package specifications do not expand the terms of Fairchild's worldwide terms and conditions, specifically the warranty therein, which covers Fairchild products.

Always visit Fairchild Semiconductor's online packaging area for the most recent package drawings:

<http://www.fairchildsemi.com/packaging/>

Ordering Information

Part Number	Package	Packing Method
FOD3184	DIP 8-Pin	Tube (50 units per tube)
FOD3184S	SMT 8-Pin (Lead Bend)	Tube (50 units per tube)
FOD3184SD	SMT 8-Pin (Lead Bend)	Tape and Reel (1,000 units per reel)
FOD3184V	DIP 8-Pin, IEC60747-5-2 option	Tube (50 units per tube)
FOD3184SV	SMT 8-Pin (Lead Bend), IEC60747-5-2 option	Tube (50 units per tube)
FOD3184SDV	SMT 8-Pin (Lead Bend), IEC60747-5-2 option	Tape and Reel (1,000 units per reel)
FOD3184TV	DIP 8-Pin, 0.4" Lead Spacing, IEC60747-5-2 option	Tube (50 units per tube)
FOD3184TSV	SMT 8-Pin, 0.4" Lead Spacing, IEC60747-5-2 option	Tube (50 units per tube)
FOD3184TSR2V	SMT 8-Pin, 0.4" Lead Spacing, IEC60747-5-2 option	Tape and Reel (700 units per reel)

Marking Information

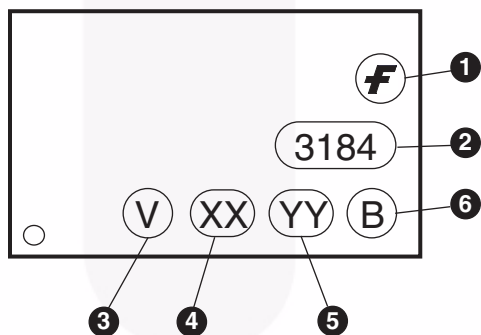

Definitions

1	Fairchild logo
2	Device number
3	VDE mark (Note: Only appears on parts ordered with IEC60747-5-2 option – See order entry table)
4	Two digit year code, e.g., '10'
5	Two digit work week ranging from '01' to '53'
6	Assembly package code

Carrier Tape Specifications – Option S

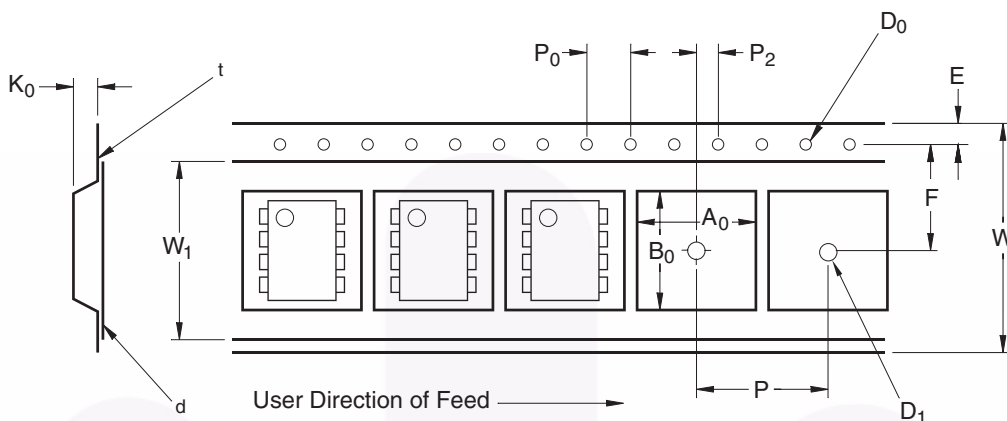

Symbol	Description	Dimension in mm
W	Tape Width	16.0 ± 0.3
t	Tape Thickness	0.30 ± 0.05
P ₀	Sprocket Hole Pitch	4.0 ± 0.1
D ₀	Sprocket Hole Diameter	1.55 ± 0.05
E	Sprocket Hole Location	1.75 ± 0.10
F	Pocket Location	7.5 ± 0.1
P ₂		2.0 ± 0.1
P	Pocket Pitch	12.0 ± 0.1
A ₀	Pocket Dimensions	10.30 ± 0.20
B ₀		10.30 ± 0.20
K ₀		4.90 ± 0.20
W ₁	Cover Tape Width	13.2 ± 0.2
d	Cover Tape Thickness	0.1 max
	Max. Component Rotation or Tilt	10°
R	Min. Bending Radius	30

Carrier Tape Specifications – Option TS

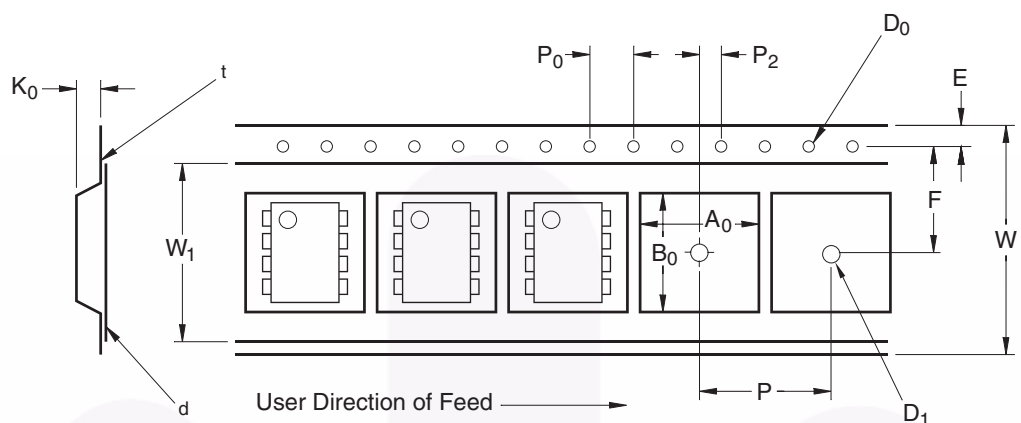

Symbol	Description	Dimension in mm
W	Tape Width	24.0 ± 0.3
t	Tape Thickness	0.40 ± 0.1
P ₀	Sprocket Hole Pitch	4.0 ± 0.1
D ₀	Sprocket Hole Diameter	1.55 ± 0.05
E	Sprocket Hole Location	1.75 ± 0.10
F	Pocket Location	11.5 ± 0.1
P ₂		2.0 ± 0.1
P	Pocket Pitch	16.0 ± 0.1
A ₀	Pocket Dimensions	12.80 ± 0.1
B ₀		10.35 ± 0.1
K ₀		5.7 ± 0.1
W ₁	Cover Tape Width	21.0 ± 0.1
d	Cover Tape Thickness	0.1 max
	Max. Component Rotation or Tilt	10°
R	Min. Bending Radius	30

Reflow Profile

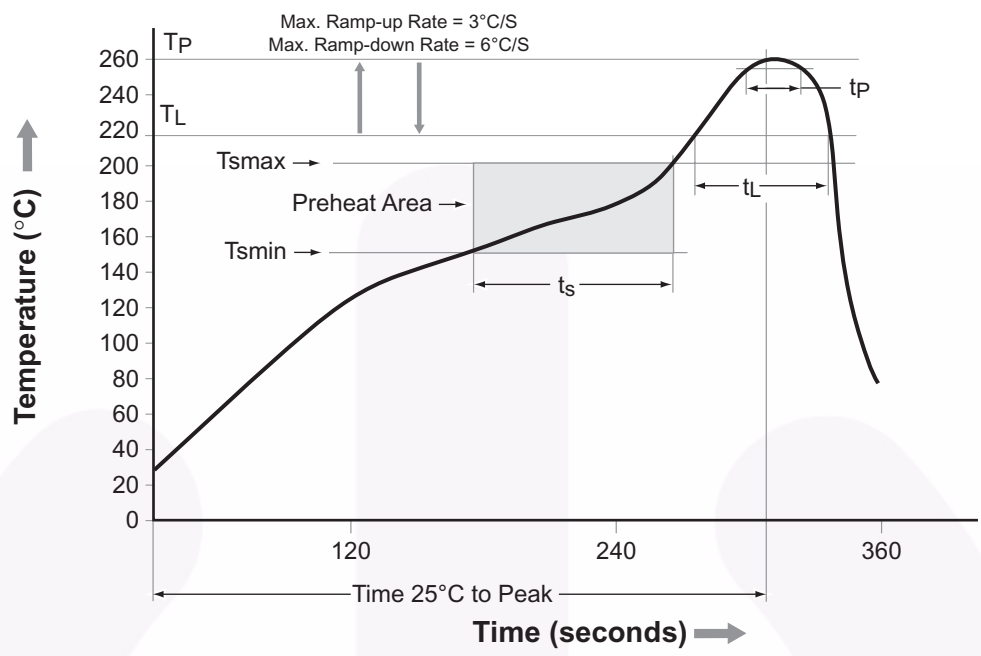

Profile Feature	Pb-Free Assembly Profile
Temperature Min. (Tsmín)	150°C
Temperature Max. (Tsmáx)	200°C
Time (ts) from (Tsmín to Tsmáx)	60–120 seconds
Ramp-up Rate (tL to tp)	3°C/second max.
Liquidous Temperature (TL)	217°C
Time (tL) Maintained Above (TL)	60–150 seconds
Peak Body Package Temperature	260°C +0°C / -5°C
Time (tp) within 5°C of 260°C	30 seconds
Ramp-down Rate (TP to TL)	6°C/second max.
Time 25°C to Peak Temperature	8 minutes max.



TRADEMARKS

The following includes registered and unregistered trademarks and service marks, owned by Fairchild Semiconductor and/or its global subsidiaries, and is not intended to be an exhaustive list of all such trademarks.

- | | | | |
|--------------------------|-------------------------------------|---------------------------------------|--|
| AccuPower™ | F-PFS™ | Power-SPM™ | <p>SYSTEM GENERAL
The Power Franchise®
the power™ franchise
TinyBoost™
TinyBuck™
TinyCalc™
TinyLogic™
TINYOPTO™
TinyPower™
TinyPWM™
TinyWire™
TriFault Detect™
TRUECURRENT™*
"SerDes"™
 SerDes™
UHC™
Ultra FRFET™
UniFET™
VCX™
VisualMax™
XS™</p> |
| Auto-SPM™ | FRFET® | PowerTrench® | |
| Build it Now™ | Global Power Resource SM | PowerXS™ | |
| CorePLUS™ | Green FPS™ | Programmable Active Droop™ | |
| CorePOWER™ | Green FPS™ e-Series™ | QFET® | |
| CROSSVOLT™ | Gmax™ | QS™ | |
| CTL™ | GTO™ | Quiet Series™ | |
| Current Transfer Logic™ | IntelliMAX™ | RapidConfigure™ | |
| DEUXPEED® | ISOPLANAR™ | ™ | |
| Dual Cool™ | MegaBuck™ | Saving our world, 1mW/W/kW at a time™ | |
| EcoSPARK® | MICROCOUPLER™ | SignalWise™ | |
| EfficientMax™ | MicroFET™ | SmartMax™ | |
| ESBC™ | MicroPak™ | SMART START™ | |
| Fairchild® | MicroPak2™ | SPM® | |
| Fairchild Semiconductor® | MillerDrive™ | STEALTH™ | |
| FACT Quiet Series™ | MotionMax™ | SuperFET™ | |
| FACT® | Motion-SPM™ | SuperSOT™-3 | |
| FAST® | OptoHIT™ | SuperSOT™-6 | |
| FastvCore™ | OPTOLOGIC® | SuperSOT™-8 | |
| FETBench™ | OPTOPLANAR® | SupreMOS® | |
| FlashWriter®* | PDP SPM™ | SyncFET™ | |
| FPS™ | | Sync-Lock™ | |

* Trademarks of System General Corporation, used under license by Fairchild Semiconductor.

DISCLAIMER

FAIRCHILD SEMICONDUCTOR RESERVES THE RIGHT TO MAKE CHANGES WITHOUT FURTHER NOTICE TO ANY PRODUCTS HEREIN TO IMPROVE RELIABILITY, FUNCTION, OR DESIGN. FAIRCHILD DOES NOT ASSUME ANY LIABILITY ARISING OUT OF THE APPLICATION OR USE OF ANY PRODUCT OR CIRCUIT DESCRIBED HEREIN; NEITHER DOES IT CONVEY ANY LICENSE UNDER ITS PATENT RIGHTS, NOR THE RIGHTS OF OTHERS. THESE SPECIFICATIONS DO NOT EXPAND THE TERMS OF FAIRCHILD'S WORLDWIDE TERMS AND CONDITIONS, SPECIFICALLY THE WARRANTY THEREIN, WHICH COVERS THESE PRODUCTS.

LIFE SUPPORT POLICY

FAIRCHILD'S PRODUCTS ARE NOT AUTHORIZED FOR USE AS CRITICAL COMPONENTS IN LIFE SUPPORT DEVICES OR SYSTEMS WITHOUT THE EXPRESS WRITTEN APPROVAL OF FAIRCHILD SEMICONDUCTOR CORPORATION.

As used herein:

- Life support devices or systems are devices or systems which, (a) are intended for surgical implant into the body or (b) support or sustain life, and (c) whose failure to perform when properly used in accordance with instructions for use provided in the labeling, can be reasonably expected to result in a significant injury of the user.
- A critical component in any component of a life support, device, or system whose failure to perform can be reasonably expected to cause the failure of the life support device or system, or to affect its safety or effectiveness.

ANTI-COUNTERFEITING POLICY

Fairchild Semiconductor Corporation's Anti-Counterfeiting Policy. Fairchild's Anti-Counterfeiting Policy is also stated on our external website, www.fairchildsemi.com, under Sales Support.

Counterfeiting of semiconductor parts is a growing problem in the industry. All manufacturers of semiconductor products are experiencing counterfeiting of their parts. Customers who inadvertently purchase counterfeit parts experience many problems such as loss of brand reputation, substandard performance, failed applications, and increased cost of production and manufacturing delays. Fairchild is taking strong measures to protect ourselves and our customers from the proliferation of counterfeit parts. Fairchild strongly encourages customers to purchase Fairchild parts either directly from Fairchild or from Authorized Fairchild Distributors who are listed by country on our web page cited above. Products customers buy either from Fairchild directly or from Authorized Fairchild Distributors are genuine parts, have full traceability, meet Fairchild's quality standards for handling and storage and provide access to Fairchild's full range of up-to-date technical and product information. Fairchild and our Authorized Distributors will stand behind all warranties and will appropriately address any warranty issues that may arise. Fairchild will not provide any warranty coverage or other assistance for parts bought from Unauthorized Sources. Fairchild is committed to combat this global problem and encourage our customers to do their part in stopping this practice by buying direct or from authorized distributors.

PRODUCT STATUS DEFINITIONS

Definition of Terms

Datasheet Identification	Product Status	Definition
Advance Information	Formative / In Design	Datasheet contains the design specifications for product development. Specifications may change in any manner without notice.
Preliminary	First Production	Datasheet contains preliminary data; supplementary data will be published at a later date. Fairchild Semiconductor reserves the right to make changes at any time without notice to improve design.
No Identification Needed	Full Production	Datasheet contains final specifications. Fairchild Semiconductor reserves the right to make changes at any time without notice to improve the design.
Obsolete	Not In Production	Datasheet contains specifications on a product that is discontinued by Fairchild Semiconductor. The datasheet is for reference information only.

Rev. 149