



EUP2589

12 String White LED Driver With Boost Controller

DESCRIPTION

The EUP2589 is a high power and high efficiency boost controller with 12-channel current sinker which is ideal for large LCD backlighting applications.

EUP2589 uses current mode, fixed frequency architecture which can clamp the inductor peak current each cycle. The switching frequency is programmable by an external frequency setting resistor. It drives an external MOSFET to boost up the output voltage from a 4.5V to 28V input supply. The EUP2589 regulates the current in each LED string to the programmed value set by an external current setting resistor. The EUP2589 current matching can achieve $\pm 1.5\%$ and regulation accuracy can reach $\pm 2\%$.

A $3\mu\text{A}$ shutdown current and 1.0V (ILED@60mA) feedback voltage and Maximum 65V output allows for up to 18 high-power LEDs in series will greatly improve efficiency and reduce power dissipation.

The device supports pulse width modulation (PWM) brightness dimming and DC voltage dimming. During digital PWM dimming, the WLED current is turned on/off at the duty cycle and frequency determined by the PWM signal on the PWMI pin. In DC voltage dimming, LEDs current turn ON/OFF frequency programmed by the capacitor from BOSC to GND.

The EUP2589 integrated multiple protect functions, such as LED Open, LED Short, Output Over voltage, Over thermal, Input Over current, and Under voltage lockout (UVLO), these protection will prevent the LCD backlight from damage.

Typical Application Circuit

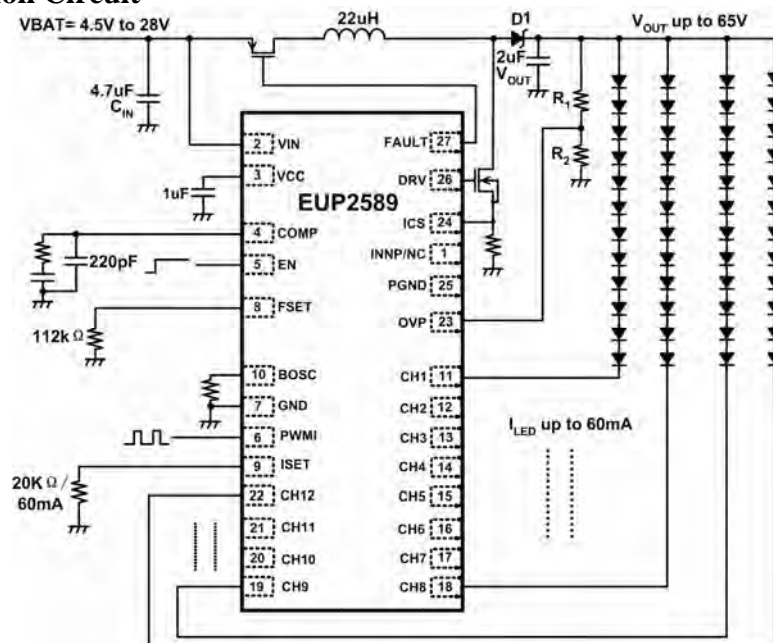

Figure 1. Typical Application circuits

FEATURES

- $3\mu\text{A}$ shutdown current
- 12 strings in parallel and up to 18 LEDs per string
- External PWM or DC Voltage Dimming Control
- Output voltage up to 65V
- Wide Input voltage range 4.5V to 28V
- Better than 1.5% LED Current Regulation Accuracy Between Strings
- Boost Switching frequency can be programmed by external resistor
- Multiple Fault Protections
 - Current Limit protection
 - Output Short circuit detection
 - Over-temperature protection
 - Output Over-voltage protection
- LED current turn off in shutdown mode
- Integrated UVLO/ Over Thermal protection
- Minimal $0.5\mu\text{s}$ LED On-Time regulation
- Thermal Enhanced 28pin TSSOP28 and SOP-28 Packages
- RoHS Compliant and 100% Lead (Pb)-Free Halogen-Free

APPLICATIONS

- LCD Monitor LED Backlighting
- LCD-TV LED Backlighting



Pin Configurations

Package Type	Pin Configurations	Package Type	Pin Configurations
TSSOP-28		SOP-28	

Pin Description

PIN	TSSOP-28	SOP-28	DESCRIPTION
1	NC	NC	Not connect.
2	VIN	VIN	Supply Voltage Input.
3	VCC	VCC	5V Linear Regulator Output to power internal circuitry. Bypass VCC to GND with a ceramic capacitor of 1μF or greater. If 4.5V < VIN < 5.5V, connect VCC directly to supply voltage of VIN.
4	COMP	COMP	Boost Converter Compensation Pin. Connect a 220nF ceramic capacitor in series with a 1k resistor from COMP to GND. When the EUP2589 shuts down, COMP is discharged to GND.
5	EN	EN	The device enable pin. A logic high signal turns on the internal LDO and enables the IC. Connect EN to VCC and make EUP2589 always ON.
6	PWMI	PWMI	Brightness Control Input. To use external PWM dimming mode, apply a PWM signal on this pin for brightness control. To use DC input PWM dimming mode, apply a DC voltage range from 0.2V to 1.2V on this pin linearly to set the internal dimming duty cycle from 0% to 100%.
7	GND	GND	Ground
8	FSET	FSET	Boost Switching Frequency Program pin. Program the boost frequency by different external resistance, $F_{BOOST} = 57000/R_{FSET}$.
9	ISET	ISET	Full-Scale LED Current Adjustment Pin. The resistance from ISET to GND controls the full-scale current in each LED string. ISET voltage is around 1.0V, during full lighting, $ICH_x = 1200/R_{ISET} \Omega$. Set $R_{ISET} = 20K\Omega$, ICH_x is set to 60mA.
10	BOSC	BOSC	Dimming Repetition Set. This is the timing pin for the oscillator to set the dimming frequency. To use DC input PWMI dimming mode, connect a capacitor from this pin to GND to set the internal dimming frequency. A triangle waveform is generated on this pin. To use external PWM dimming mode, connect a resistor from BOSC to GND set its voltage to about 0.7V, and apply the PWM signal on DBRT pin.
11~22	CH1~CH12	CH1~CH12	Channel 12~1 LED current source. Leave it floating if not used.
23	OVP	OVP	Output over-voltage feedback input. Connect OVP to the tap point of the resistor divider between output and ground.
24	ICS	ICS	Current Sense Input. During normal operation, this pin senses the voltage across the external inductor current sensing resistor for peak current mode control and also to limit the inductor current during every switching cycle.
25	PGND	PGND	Power Ground
26	DRV	DRV	External N-CH Power Device Gate Driver Output. This pin provides the boost converter power device gate drive signal.

Pin Description

PIN	TSSOP-28	SOP-28	DESCRIPTION
27	FAULT	FAULT	Fault Disconnection Switch Gate Output. When the system starts up normally, this pin smoothly turns on the external PMOS. When the EUP2589 is disabled, the external PMOS is turned off to disconnect the input and output.
28	NC	NC	Not connect
Thermal Pad	GND	-	CH1~CH12 current mirror Ground.

Ordering Information

Order Number	Package Type	Marking	Operating Temperature Range
EUP2589XIR1	TSSOP-28 (EP)	XXXXX EUP2589	-40 °C to +85°C
EUP2589YIR1	SOP-28	XXXXX EUP2589	-40 °C to +85°C

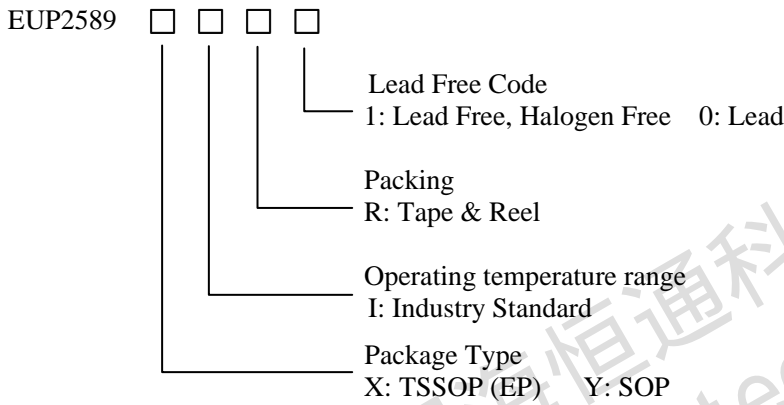

Block Diagram

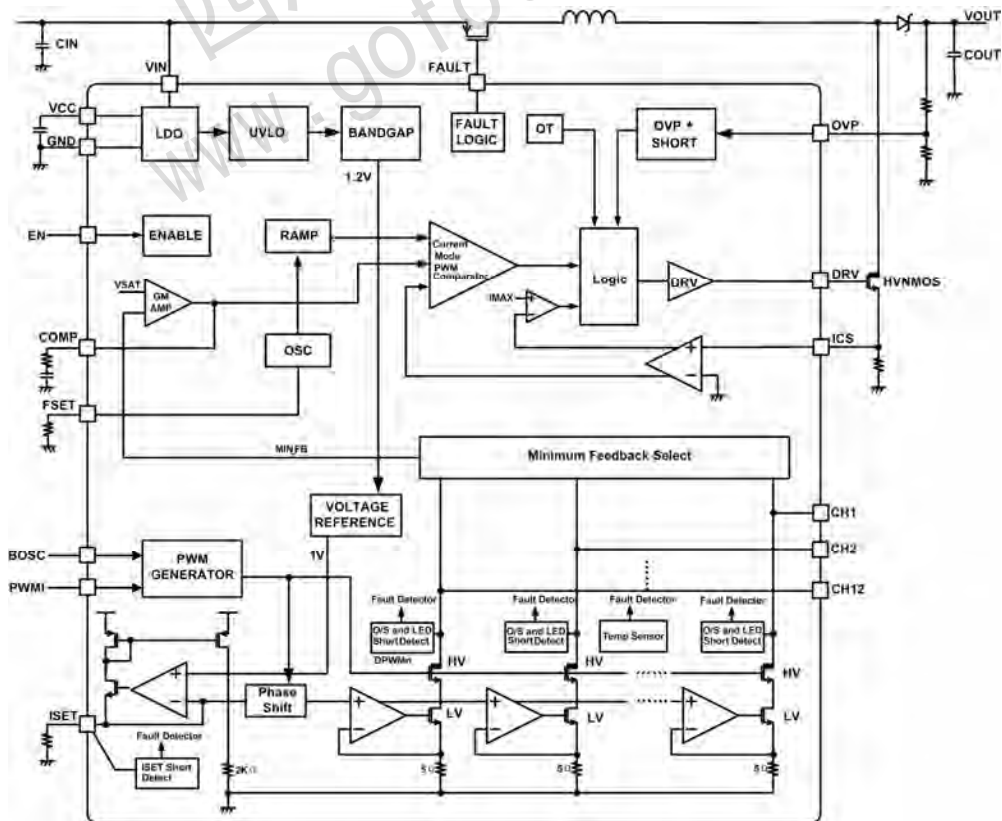

Figure 2. Block Diagram

Absolute Maximum Ratings (1)

- CH (n), ICS to GND ----- -0.3V to 65V
- VIN, FAULT to GND ----- -0.3V to 30V
- PGND to GND ----- -0.3V to +0.3V
- COMP, OVP, DRV, PWMI, EN, ISET, FSET, BOSC, VCC to GND ----- -0.3V to +6V
- Continuous Power Dissipation (T_A = +70°C)
 - 28-Pin TSSOP [derate 29.4mW/°C (JEDEC high-k 2s2p) above +70°C] ----- 2353mW
 - 28-Pin SOP [derate 16.67mW/°C (JEDEC high-k 2s2p) above +70°C] ----- 1333mW
- Operating Temperature Range ----- -40°C to +85°C
- Maximum Junction Temperature ----- +150°C
- Storage Temperature Range ----- -60°C to +150°C
- Lead Temperature (soldering, 10s) ----- +300°C

Operating Conditions (2)

- Operating Temperature Range ----- -40°C to +85°C
- Supply Voltage , VIN----- 4.5V to 28V

Note (1): Stress beyond those listed under “Absolute Maximum Ratings” may damage the device.

Note (2): The device is not guaranteed to function outside the recommended operating conditions.

Electrical Characteristics

(Circuit of Figure 1, VIN=12V, GND=PGND=0V, R_{ISET}=20kΩ, V_{PWMI}= 5V, T_A= 40°C to +85°C, unless otherwise noted. Typical values are at T_A= +25°C.)

Symbol	Parameter	Conditions	EUP2589			Unit
			Min.	Typ.	Max.	
VIN	VIN Supply voltage		4.5		28	V
I _{VIN}	VIN Supply current	PWMI=5V		2.5	5	mA
I _{OFF}	VIN Shutdown Current	PWMI=0V, EN=0, VIN=12V			6	μA
VCC	VCC Output Voltage	VEN=5V, 6V<VIN<28V, 0<I _{VCC} <10mA	4.5	5	5.5	V
I _{VCC}	VCC Current Limit			50		mA
UVLO	UVLO Rising		3.7	4.1	4.4	V
UVLO_HYS	UVLO Hyteresis			0.15		V
VIH	EN High Level	VEN Rising	1.5			V
VIL	EN Low Level	VEN Falling			0.8	V
Boost Converter						
	DRV Sourcing Impedance	VIN=VCC=5V, IDR _V =5mA		15		Ω
	DRV Sinking Impedance	VIN=VCC=5V, IDR _V =5mA		4		Ω
FSW	Switching Frequency	R _{FSET} =112KΩ	475	500	525	KHz
TON_MIN	Minimum ON Time			100		nS
ICS	Boost Current Limit		0.28	0.3	0.32	V
DMAX	Maximum Duty Cycle		90	93	96	%
GM	COMP Transconductance	ΔI _{COMP} =±10μA		60		μS
LED Current Regulation						
RCH	CHn Sink Resistance	I _{LEDn} =60mA, V _{CH} =1V		15		Ω
VISET	ISET Regulation Voltage			1		V
I _{LED}	Output LED Current	R _{ISET} =20KΩ	57.6	60	62.4	mA
Imatch	CHn Current matching	I _{LED} =60mA	-1.5		1.5	%

Electrical Characteristics (continued)

(Circuit of Figure 1, $V_{IN}=12V$, $GND=PGND=0V$, $R_{ISET}=20k\Omega$, $V_{PWMI}=5V$, $T_A=40^\circ C$ to $+85^\circ C$, unless otherwise noted. Typical values are at $T_A=+25^\circ C$.)

Symbol	Parameter	Conditions	EUP2589			Unit
			Min.	Typ.	Max.	
Dimming Controls						
TPWMImin	Minimum PWM Pulse	In External PWM Dimming Mode		0.5		μs
VPWMH	PWMI Input high level		1.5		V_{IN}	V
VPWML	PWMI input low level		0		0.4	V
IPWMI	PWMI Pull Down current	$V_{PWMI}=5V$	-1		+1	μA
Fault Detections						
Vovp	Over-voltage Threshold on OVP	Rising Edge	1.2	1.25	1.3	V
Vhys-ovp	OVP Hysteresis	Falling Edge		80		mV
VCHx_OV	CHx Over Voltage Threshold	$V_{IN}>5.5V$	5.1	5.5	5.9	V
IFault	FAULT Pull Down Current		40	55	70	μA
VFAULT	FAULT Clamp Voltage	$V_{IN}=12V$, $V_{FAULT}=V_{IN}-V_{FAULT}$		6		V
Tsd	Thermal Shutdown Threshold			150		$^\circ C$
Tsd_hys	Thermal shutdown hysteresis			30		$^\circ C$

Typical Operating Characteristics

Efficiency vs. Input Voltage

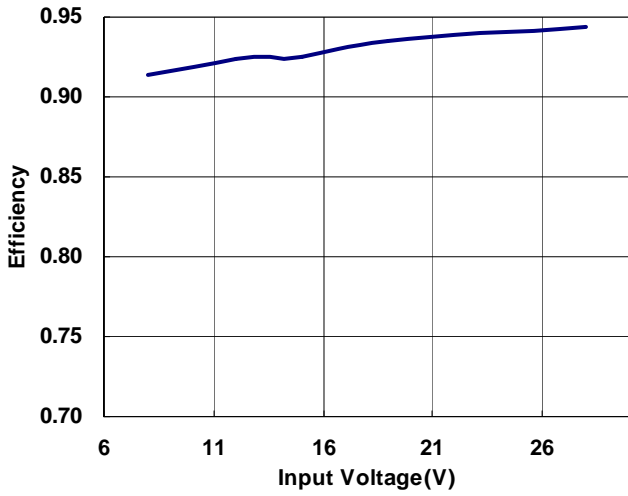

Steady State

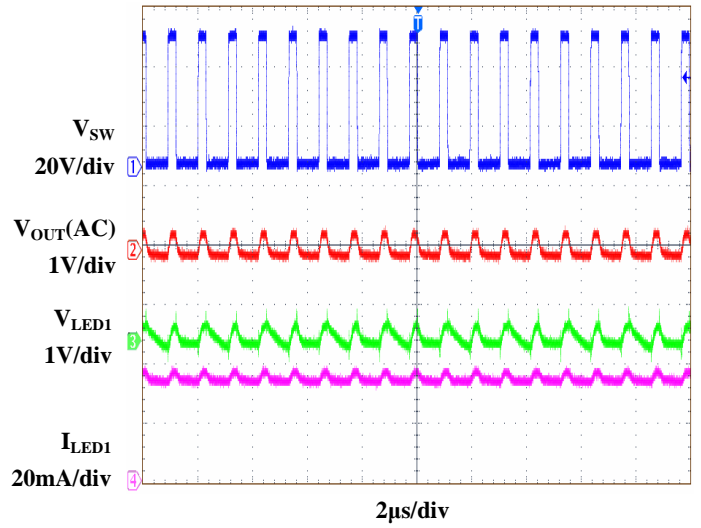

V_{IN} Startup

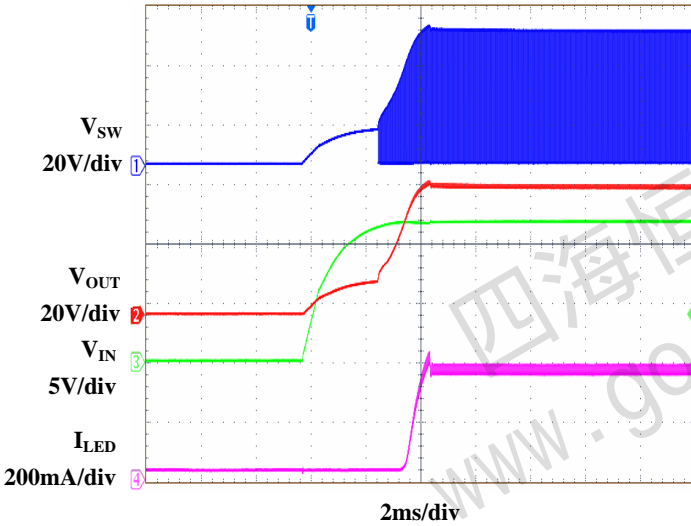

V_{EN} Startup

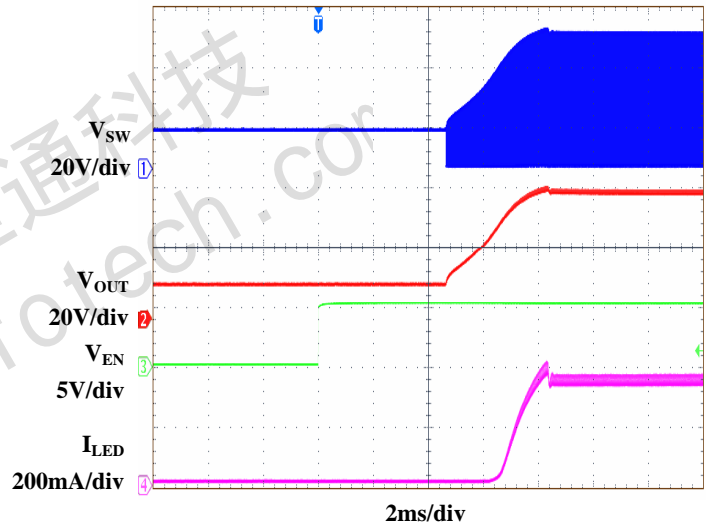

DC Burst Dimming

$V_{PWM1}=0.4V, C_{BOSC}=2.0nF$

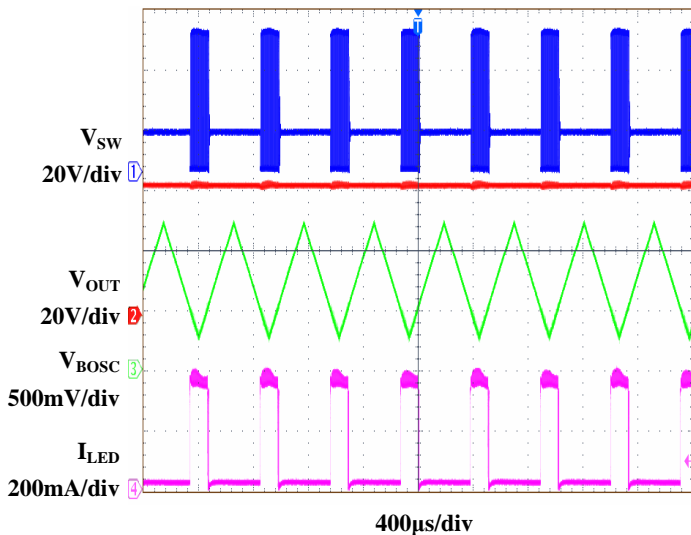

External PWM Dimming

$f_{PWM}=200Hz, D_{PWM}=50\%$

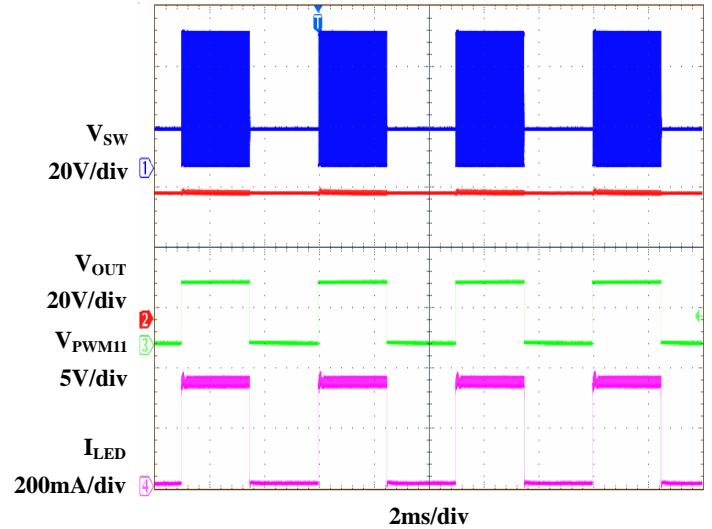

Typical Operating Characteristics (Continued)

Open LED Protection
Open all LED strings at working

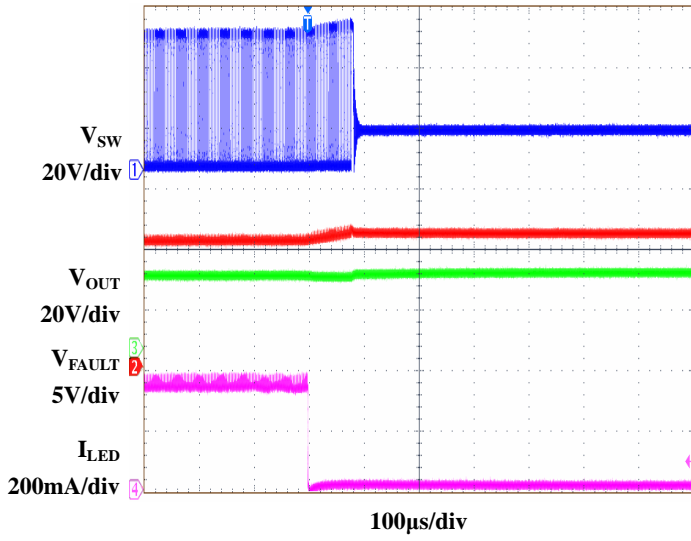

Short LED Protection
Short V_{OUT} to GND at working

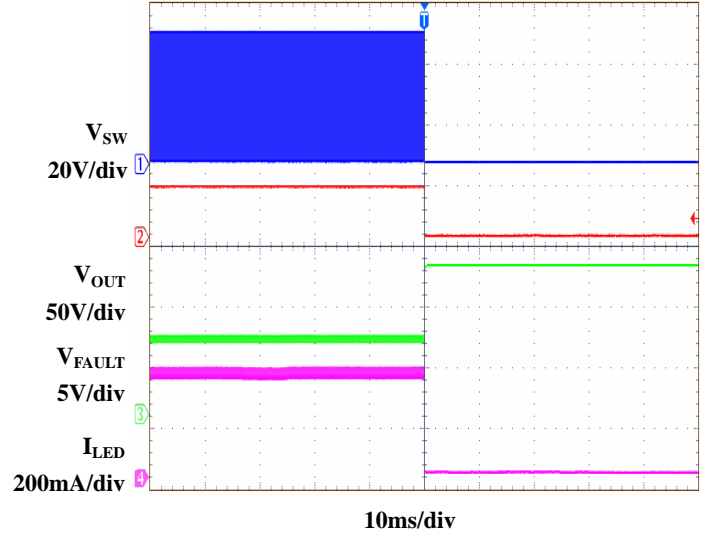

四海恒通科技
www.gofotech.com

Detailed Descriptions

The EUP2589 is a high-efficiency driver for arrays of white LEDs. It contains a fixed-frequency, current mode, PWM step-up controller, 5V linear regulator, dimming control circuit, and 12 regulated current sources (see Figure 2). When enabled, the step-up controller boosts the output voltage to provide sufficient headroom for the current sources to regulate their respective string currents. The EUP2589 features programmable switching frequency, which allows trade-offs between external component size and operating efficiency. The control architecture automatically skips pulses at light loads to improve efficiency and prevents overcharging the output capacitor. The EUP2589 supports both analog and digital control of the LED current through a PWM logic input signal or DC level on PWMI. The EUP2589 has multiple features to protect the controller from fault conditions. Separate feedback loops limit the output voltage if one or more LEDs fail open or short. The controller features cycle-by-cycle current limit to provide consistent operation and soft-start capability. A thermal-shutdown circuit provides another level of protection. This part includes a 5V linear regulator that provides the internal bias and gate drive for the step-up controller. When an external 5V is available, the internal LDO can be overdriven to decrease power dissipation. Otherwise, connect the VIN pin to an input greater than 5.5V. An internal crude LDO keeps alive to provide power supply for internal logic and controller even EN is low, which only dissipate 3 μ A quiescent current.

5V Supply VCC and UVLO

The EUP2589 has built in 5V linear regulator VCC supply for internal control voltage. The EUP2589 includes the power on reset (POR) and under-voltage lockout (UVLO) features. POR resets the fault latches. POR occurs when VCC rises above 2.8V (typ). The controller is disabled until VCC exceeds the UVLO threshold of 4.05V (typ). Hysteresis on UVLO is approximately 150mV. The VCC should be bypassed to GND with a 0.47 μ F or greater ceramic capacitor.

System Startup

When the EUP2589 is enabled, the chip checks the topology connection first. The FAULT pin drives the external Fault Disconnection PMOS to turn on slowly. And after 8mS delay, the chip monitors the OVP pin to see if the Schottky diode is not connected or the boost output is short to GND. If the OVP voltage is lower than 70mV, the chip will be disabled and the external PMOS is turned off together. It is recommended on the start up sequence that the enable signal comes after input voltage and PWM dimming signal established.

Step-up Converter

The converter operation frequency is programmable (from 150kHz to 1MHz) with a external set resistor on FSET pin, which is helpful for optimizing the external components sizes and improving the efficiency. An oscillator resistor on FSET pin sets the internal oscillator frequency for the step-up converter according to the equation:

$$F_{SW} = 57000 / R_{FSET}$$

For $R_{FSET}=112k\Omega$, the switching frequency is set to 500kHz.

The EUP2589's fixed-frequency, current-mode, step-up controller automatically chooses the lowest active CHx voltage to regulate the output voltage. When $I_{LED}=60mA$, a 1.0v is setting as the minimum CHx feedback reference. The error signal is compared to the external switch current plus slope compensation to determine the switch on-time. As the load changes, the error amplifier sources or sinks current to the COMP output to deliver the required peak-inductor current. The slope-compensation signal is added to the current-sense signal to improve stability at high duty cycles.

At light-load or V_{out} near to V_{in} operation, the converter runs into the pulse-skipping mode, the FET is turned on for a minimum on-time of approximately 100ns, and then the converter discharges the power to the output in the remain period. The external MOSFET will keep off until the output voltage needs to be boosted again.

Dimming Control

The EUP2589 provides two PWM dimming methods: external PWM signal or DC input PWM Dimming mode. Both methods results in PWM chopping of the current in the LEDs for all 12 channels to provide LED control.

When bias the BOSC pin to a DC level, applying a PWM signal to the PWMI pin to achieve the PWM dimming. A DC analog signal can be directly applied to the PWMI pin to modulate the LED current. And the DC signal is then converted to a DPWM dimming signal at the setting oscillation frequency. The brightness of the LED array is proportional to the duty cycle of the DPWM signal. The DPWM signal frequency is set by the cap at the BOSC pin.

1. Direct PWM Dimming

An external PWM dimming signal is employed to achieve PWM dimming control. Connect a 100k Ω resistor from BOSC pin to GND and apply the 100Hz to 2kHz PWM dimming signal to PWMI pin. The minimum recommended amplitude of the PWM signal is 1.5V (See Figure 3).

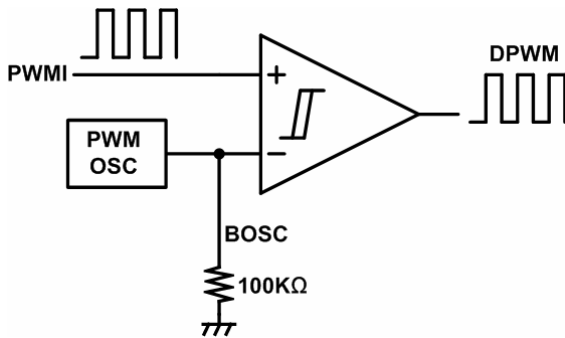

Figure 3. Direct PWM Dimming

2. DC Input PWM Dimming

To apply DC input PWM dimming, apply an analog signal (range from 0 V to 1.2V) to the PWMI pin to modulate the LED current directly. If the PWMI is applied with a zero DC voltage, the PWM duty cycle will be 0%. If the DBRT pin is applied with a DC voltage > 1.2V, the output will be 100% (See Figure 4). The capacitor on BOSC pin set the frequency of internal triangle waveform according to the equation:

$$F_{BOSC} = 3.5\mu\text{F} / C_{BOSC}$$

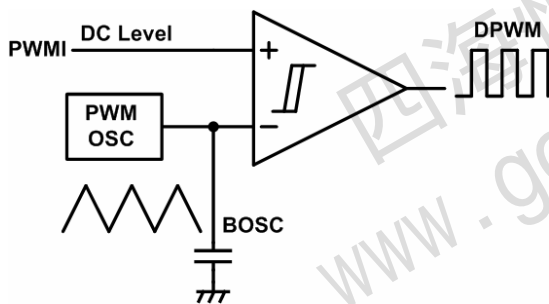

Figure 4. DC Input PWM Dimming

Open String Protection

The open string protection is achieved through the over voltage protection. If one or more strings are open, the respective CHx pins are pulled to ground and the IC keeps charging the output voltage until it reach OVP threshold. Then the part will mark-off the open strings whose CHx pin voltage is less than 210mV. Once the mark off operation completes, the remaining LED strings will force the output voltage back into tight regulation. The string with the highest voltage drop is the ruling string during output regulation.

The EUP2589 always tries to light at least one string and if all strings in use are open, the EUP2589 shuts down the step-up converter. The part will maintain mark-off information until the part shuts down.

Setting the Over Voltage Protection

The open string protection is achieved through the over voltage protection (OVP). In some cases, an LED string failure results in the feedback voltage always zero. The part then keeps boosting the output voltage higher and higher. If the output voltage reaches the programmed OVP threshold, the protection function will be triggered. To make sure the chip functions properly, the OVP setting resistor divider must be set with a proper value. The recommended OVP point is about 1.2 times higher than the output voltage for normal operation.

$$V_{OVP} = 1.23 \times \left(\frac{R_1 + R_2}{R_2} \right)$$

Short String Protection

The EUP2589 monitors the CHx pin voltage to judge if the short string occurs. If one or more strings are shorted, the respective CHx pins will be pulled up to the boost output and tolerate high voltage stress. If the CHx pin voltage is higher than 5.5V, the short string condition is detected on the respective string. When the short string fault (CHx over-voltage fault) continues for greater than 2ms, the string is marked off and disabled. Once a string is marked off, its current regulation is forced to disconnect from the output voltage loop regulation. The marked-off LED strings will be shut off totally until the part restarts. If all strings in used are short, the EUP2589 will shut down the step-up converter.

Fault Protection

The EUP2589 has multiple features to protect the device from fault conditions. Separate feedback loops limit the output voltage under any circumstance, ensuring safe operation. Once an open string is detected, the string is disabled while other strings operate normally. The EUP2589 also features short LED detection. Table 1 lists all the EUP2589 fault protections control.

Table 1. EUP2589 Fault Protection

Faults	FAULT Output (HV)	IC Operation Mode	Boost DC-DC	WLED Current
CHx Short to GND	Pull Lo, Enable PCH	Normal	Only 12CHx All OFF, Controller will Shutdown. Otherwise, Keep Normal	Mark OFF the shorted CHx, Others keep Normal
CHx Over Voltage	Pull Lo, Enable PCH	Normal	Only 12CHx All OFF, Controller will Shutdown. Otherwise, Keep Normal	Mark OFF the LED Open CHx, Others keep Normal
OVP shorted to GND or Boost Schottky Diode Malfunction ($V_{OVP} < 0.07V$)	Pull Hi, Disable PCH	Normal	Off	Off
DC-DC Boost Output Exceeds OVP Threshold ($V_{OVP} = 1.23V$)	Pull Lo, Enable PCH	Normal	When V_{OVP} is greater than 1.23V, the boost controller will be turned off until V_{OVP} drops to 1.18V.	On
Thermal Fault ($T_J > +150^{\circ}C$)	Pull Lo, Enable PCH	Normal	Off first, Then Return to soft-start after T_J falls below 120°C	Off first, Then Return to soft-start after T_J falls below 120°C
EN Lo	Pull Hi, Disable PCH	Shutdown, $I_Q < 6\mu A$	Off	Off

Packaging Information

TSSOP-28

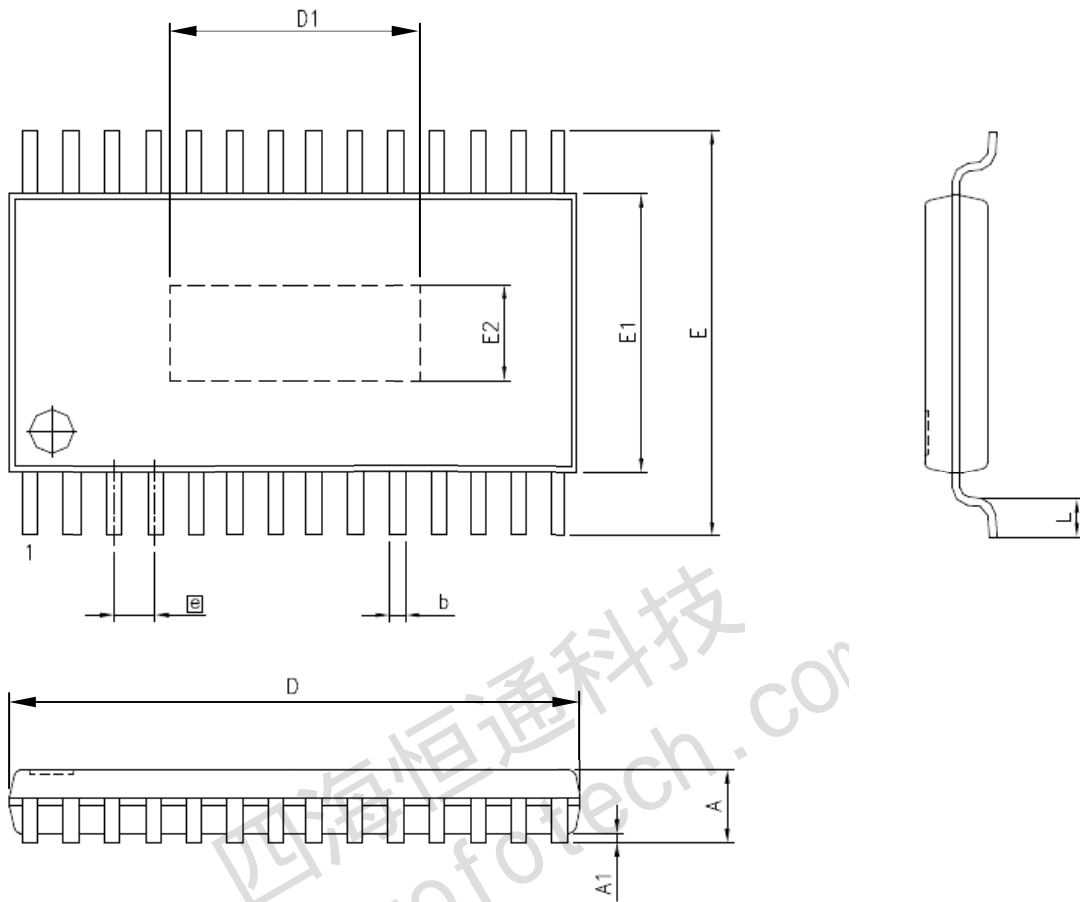

SYMBOLS	MILLIMETERS		INCHES	
	MIN.	MAX.	MIN.	MAX.
A	-	1.20	-	0.047
A1	0.00	0.15	0.000	0.006
b	0.19	0.30	0.007	0.012
E1	4.40		0.173	
D	9.60	9.80	0.378	0.386
D1	3.05	3.55	0.120	0.139
E	6.20	6.60	0.244	0.260
E2	2.62	3.12	0.103	0.122
e	0.65		0.026	
L	0.45	0.75	0.018	0.030

SOP-28

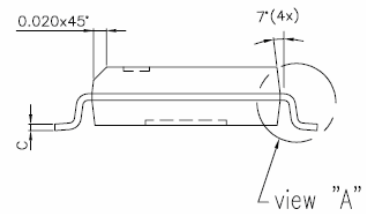
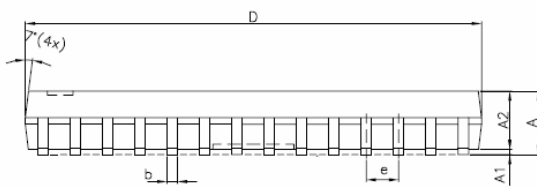
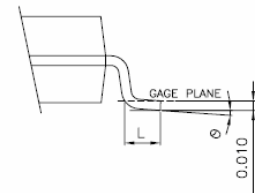
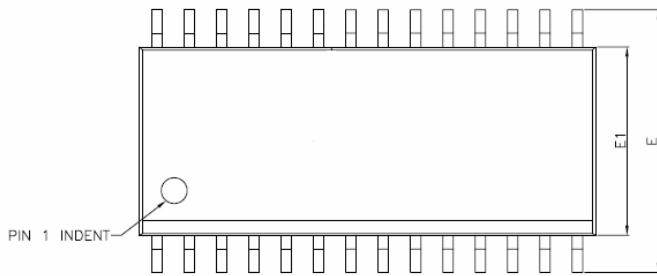

SYMBOLS	MILLIMETERS			INCHES		
	MIN.	NOM.	MAX.	MIN.	NOM.	MAX.
A	2.36	2.49	2.64	0.093	0.098	0.104
A1	0.10	—	0.30	0.004	—	0.012
A2	—	2.34	—	—	0.092	—
b	0.33	0.41	0.51	0.013	0.016	0.020
C	0.23	0.25	0.30	0.009	0.010	0.012
D	17.70	17.91	18.11	0.697	0.705	0.713
E	10.01	10.31	10.64	0.394	0.406	0.419
E1	7.39	7.49	7.59	0.291	0.295	0.299
e	1.27 BSC			0.050 BSC		
L	0.38	0.81	1.27	0.015	0.032	0.050
θ	0°	—	8°	0°	—	8°