

23V 3A Step-Down DC/DC Converter

FEATURES

- 3A Continuous Output Current
- Programmable Soft Start
- 100mΩ Internal Power MOSFET Switch
- Stable with Low ESR Output Ceramic Capacitors
- Up to 95% Efficiency
- 22μA Supply Current in Shutdown Mode
- Fixed 385KHz Frequency
- Thermal Shutdown
- Cycle by Cycle Over Current Protection
- Wide 4.75 to 23V Operating Input Range
- Output Adjustable from 1.22V to 16V
- Under Voltage Lockout

DESCRIPTION

The AIC2565 is a high efficiency, step-down DC/DC converter that builds in a high side power MOSFET. It offers continuous 3A output current over a very wide input voltage range with excellent load and line regulation.

Well-performed current mode operation makes fast transient response and feedback loop stabilization easier.

The AIC2565 draws only 22μA supply current in shutdown mode. Current limit and thermal shutdown function are also provided to prevent damage. The AIC2565 is available in an 8-pin SOP exposed pad package.

APPLICATIONS

- Networking Products
- Distributed Power Systems
- Battery Charger
- Pre-Regulator for Linear Regulators.

TYPICAL APPLICATIONS CIRCUIT

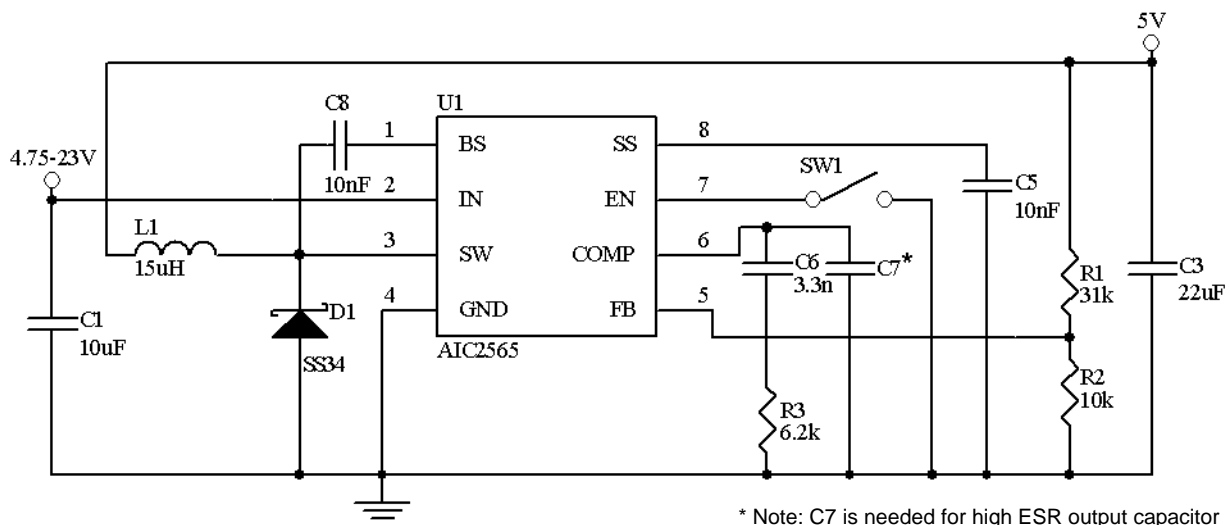

ORDERING INFORMATION

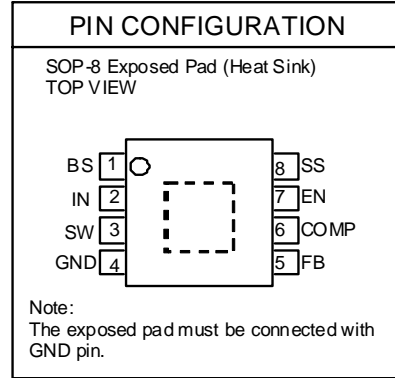
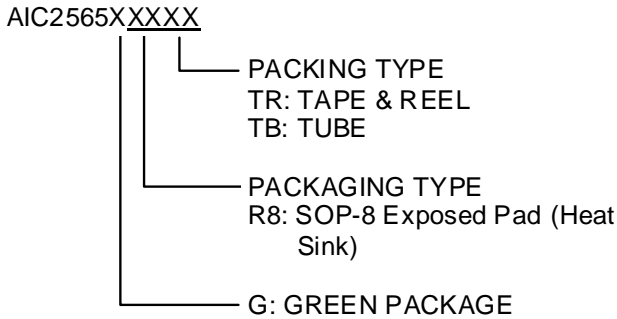

Example:

AIC2565GR8TR
 → GREEN SOP-8 Exposed Pad(Heat Sink) Package
 and TAPE & REEL Packing Type

ABSOLUTE MAXIMUM RATINGS

Input Voltage (V_{IN})	24V
SW pin Voltage (V_{SW})	25V
BS Pin Voltage	$V_{SW}+6V$
All Other Pins Voltage	-0.3V to 6V
Operating Ambient Temperature Range T_A	-40°C~85°C
Operating Maximum Junction Temperature T_J	150°C
Storage Temperature Range T_{STG}	-65°C~150°C
Lead Temperature (Soldering 10 Sec.)	260°C
Thermal Resistance Junction to Case SOP-8 Exposed Pad*	15°C/W
Thermal Resistance Junction to Ambient SOP-8 Exposed Pad*	60°C/W

(Assume no Ambient Airflow)

Absolute Maximum Ratings are those values beyond which the life of a device may be impaired.

*The package is place on a two layers PCB with 2 ounces copper and 2 square inch, connected by 8 vias.

■ ELECTRICAL CHARACTERISTICS
(V_{IN}=12V, unless otherwise specified. Typical values are at T_A=+25°C) (Note1)

PARAMETER	SYMBOL	CONDITIONS	MIN	TYP	MAX	UNITS
Shutdown Supply Current		V _{EN} = 0V		22	36	μA
Supply Current		V _{EN} ≥ 3V, V _{FB} = 1.4V		0.6	1.3	mA
Feedback Voltage	V _{FB}	4.75V ≤ V _{IN} ≤ 23V	1.194	1.222	1.250	V
Error Amplifier Voltage Gain	A _{VEA}			400		V/V
Erro Amplifier Transconductance	G _{EA}	Δ I _{COMP} = ± 10μA	500	800	1120	μA/V
High-Side Switch On-Resistance	R _{DS(ON)1}			100		mΩ
Low-Side Switch On-Resistance	R _{DS(ON)2}			10		Ω
High-Side Switch Leakage Current		V _{EN} = 0V, V _{SW} = 0V		0	10	μA
Current Limit			3.6	5.0		A
Current Sense to COMP Transconductance	G _{CS}			3.8		A/V
Oscillation Frequency	f _s		335	385	435	KHz
Short Circuit Oscillation Frequency		V _{FB} = 0V		120		KHz
Maximum Duty Cycle	D _{MAX}	V _{FB} = 0.8V		90		%
Minimum Duty Cycle	D _{MIN}	V _{FB} = 1.5V			0	%
Shutdown Threshold			1.1	1.5	2.0	V
Enable Pull Up Current		V _{EN} = 0V		1.0	2.5	μA
Under Voltage Lockout Threshold		V _{IN} Rising	3.6	4.0	4.4	V
Under Voltage Lockout Threshold Hysteresis				210		mV
Soft Start Period		C _{SS} = 0.1μF		10		ms
Thermal Shutdown				160		°C

Note 1: Specifications are production tested at T_A=25°C. Specifications over the -40°C to 85°C operating temperature range are assured by design, characterization and correlation with Statistical Quality Controls (SQC).

TYPICAL PERFORMANCE CHARACTERISTICS

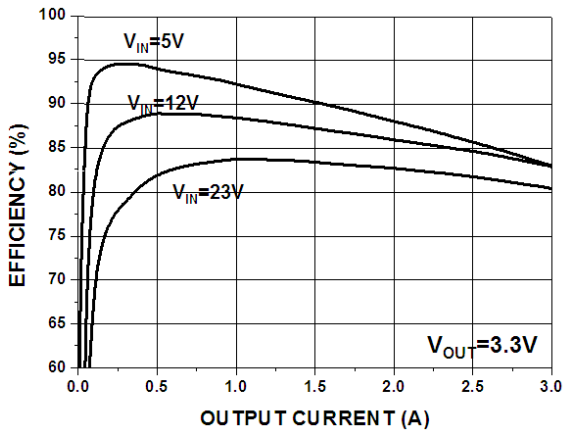

Fig. 1 Efficiency vs. Load Current

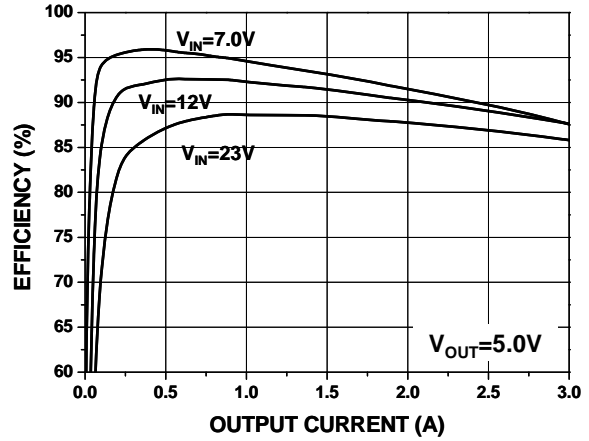

Fig. 2 Efficiency vs. Load Current

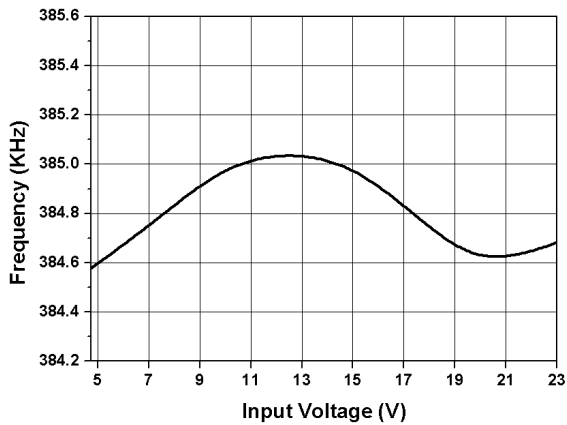

Fig. 3 Switching Frequency vs. Input Voltage

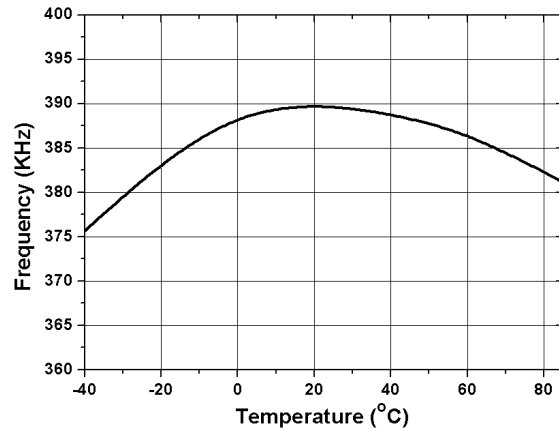

Fig. 4 Switching Frequency vs. Temperature

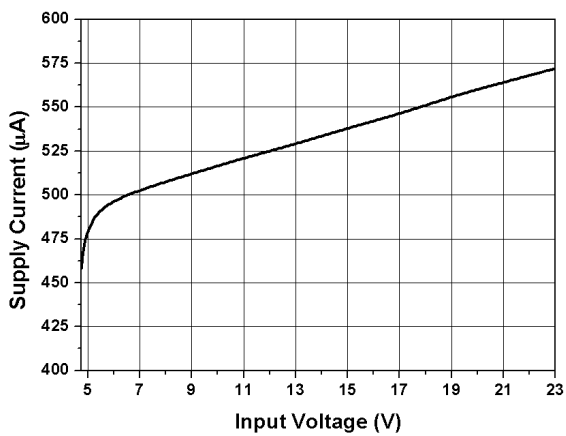

Fig. 5 Supply Current vs. Input Voltage

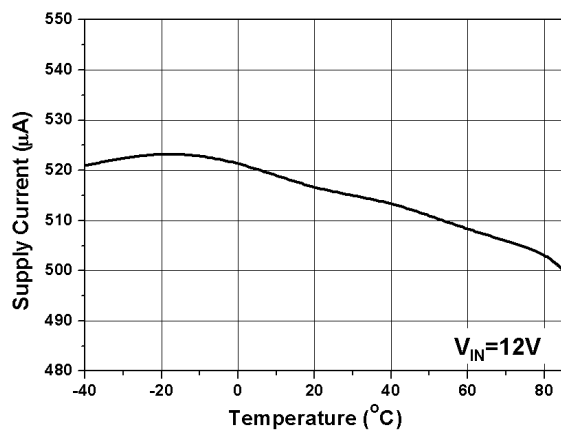

Fig. 6 Supply Current vs. Temperature

TYPICAL PERFORMANCE CHARACTERISTICS (Continued)

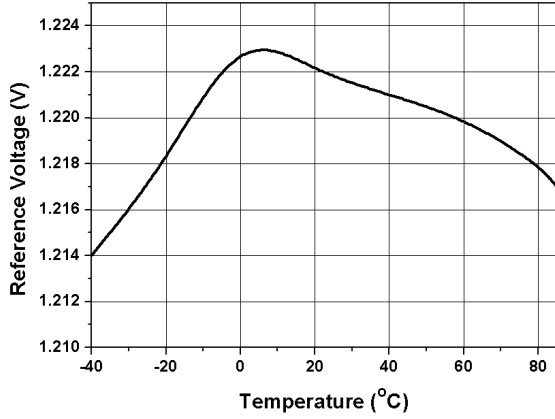

Fig. 7 V_{REF} vs. Temperature

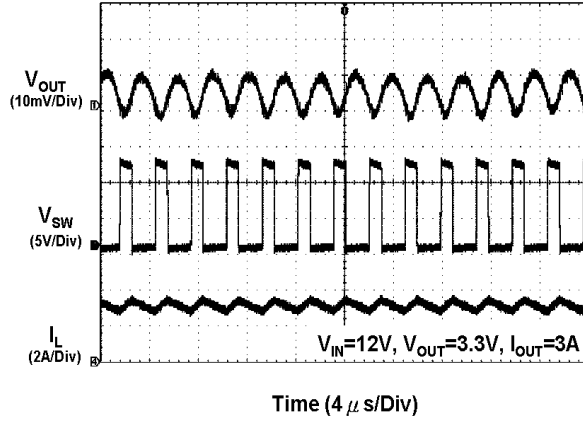

Fig. 8 Output Ripple Voltage

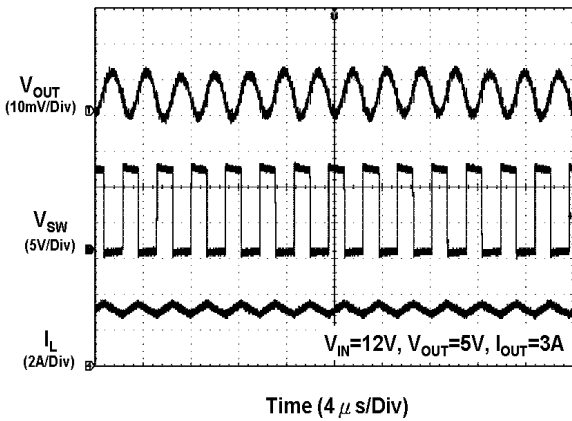

Fig. 9 Output Ripple Voltage

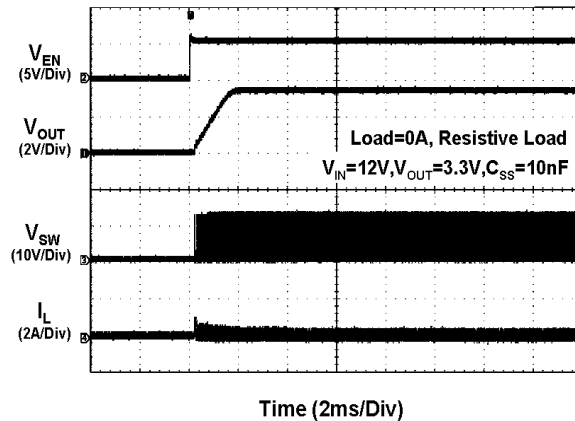

Fig. 10 Startup

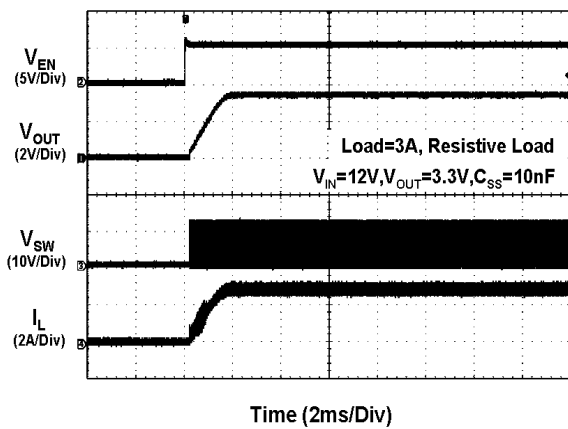

Fig. 11 Startup

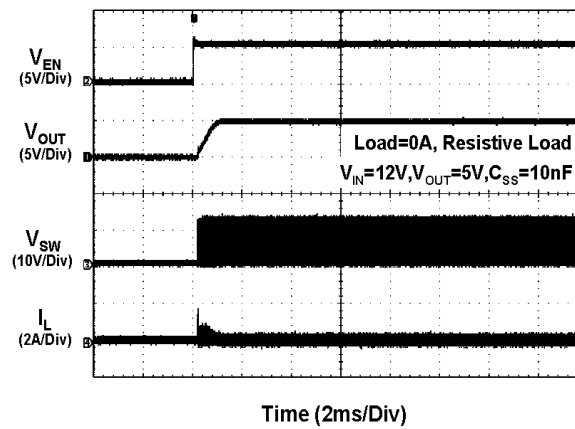

Fig. 12 Startup

■ TYPICAL PERFORMANCE CHARACTERISTICS (Continued)

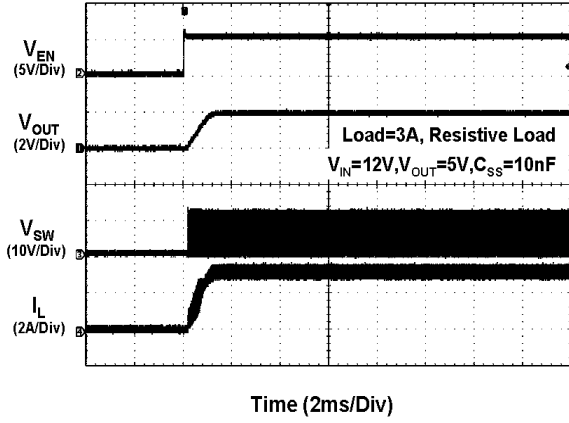

Fig. 13 Startup

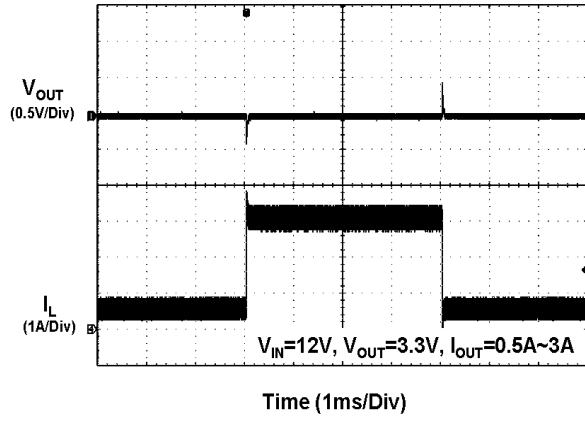

Fig. 14 Load Transient Response

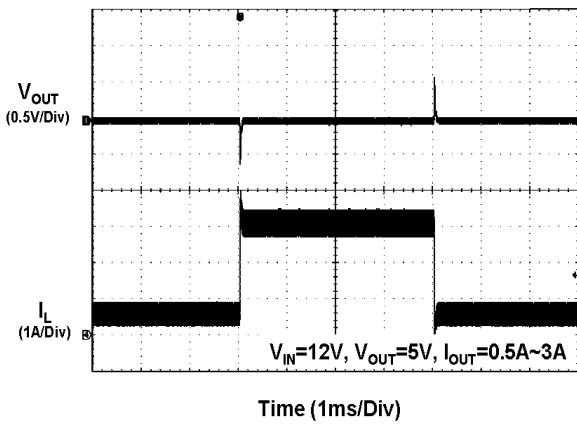
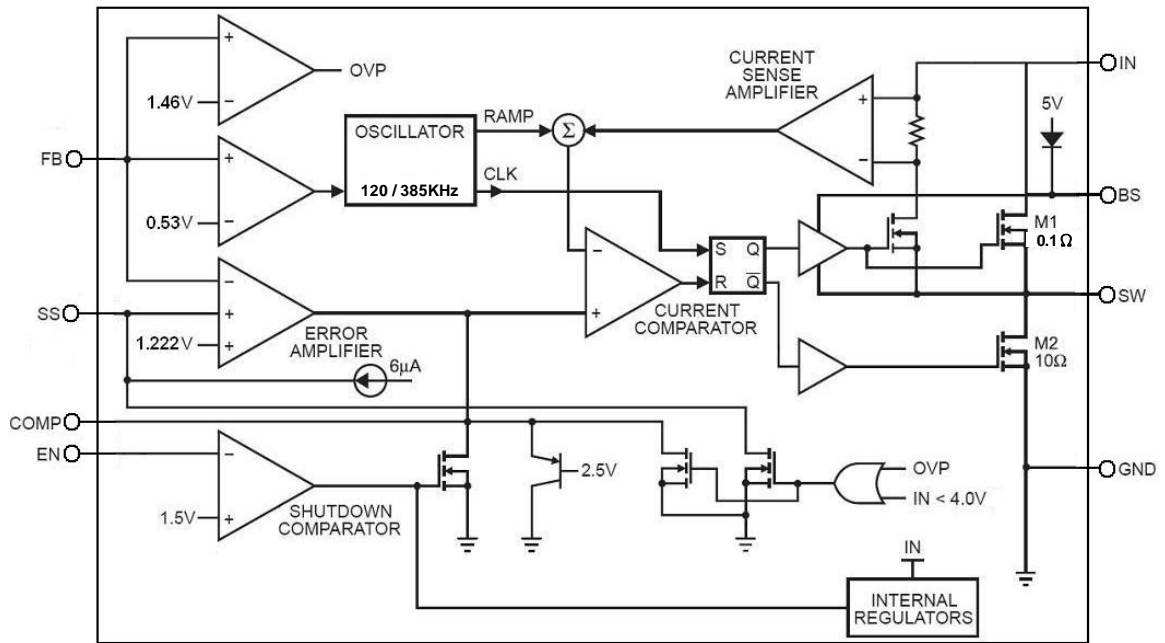

Fig. 15 Load Transient Response

■ BLOCK DIAGRAM



Functional Block Diagram of AIC2565

■ PIN DESCRIPTIONS

- PIN1: BS:** High Side Gate Drive Boost Input. BS supplies the drive for the high-side N-Channel MOSFET switch. Connect a 10nF or greater capacitor from SW to BS to power the high-side switch.
- PIN2: IN:** Power Input. IN supplies the power to the IC, as well as the step-down converter switches. Drive IN with a 4.75 to 23V power source. By pass IN to GND with a suitable large capacitor to eliminate noise on the input to the IC.
- PIN3: SW:** Power Switching Output. SW is the switching node that supplies power to the output. Connect the output LC filter from switch to the output load. Note that a capacitor is required from SW to BS to power the high-side switch.
- PIN4: GND:** Ground.
- PIN5: FB:** Feedback Input. FB senses the output voltage to regulate that voltage. Drive feedback with a resistive voltage divider from the output voltage.
- PIN6: COMP:** Compensation Node. COMP is used to compensate the regulation control loop. Connect a series RC network from COMP to GND to compensate the regulation control loop. In some cases, an additional capacitor from COMP to GND is required.
- PIN 7: EN:** Enable Input. EN is a digital input that turns the regulator on or off. Drive EN high to turn on the regulator. Drive it low to turn it off. For automatic start-up, leave EN unconnected.
- PIN 8: SS:** Soft Star Control Input. SS controls the soft star period. Connect a capacitor from SS to GND to set the soft-star period. To disable the soft-star feature, leave the SS pin unconnected.

■ COMPONENT SELECTION

V _{IN} (V)	V _{OUT} (V)	L ₁ (μH)	C ₃ (μF)	R ₃ (kΩ)	C ₆ (nF)	R ₁ (kΩ)	R ₂ (kΩ)
12	1.8	6.8 (COOPER BUSSMANN DR125-6R8-R)	22 ceramic (Taiyo Yuden EMK325BJ226MM-T)	2.2	8.2	4.75	10
12	2.5	10 (COOPER BUSSMANN DR1050-100-R)	22 ceramic (Taiyo Yuden EMK325BJ226MM-T)	3.0	6.8	11	10
12	3.3	15 (COOPER BUSSMANN DRQ125-150-R)	22 ceramic (Taiyo Yuden EMK325BJ226MM-T)	5.6	3.9	17	10
12	5.0	15 (COOPER BUSSMANN DRQ125-150-R)	22 ceramic (Taiyo Yuden EMK325BJ226MM-T)	6.2	3.3	31	10

■ APPLICATION INFORMATION

● Operation

The AIC2565 is a fixed-frequency and high efficiency step-down DC/DC converter with current-mode PWM control architecture. By selecting appropriate circuit components, it can achieve fast transient response. During normal operation, the AIC2565 can regulate its output voltage through a feedback control circuit, which is composed of an error amplifier; a current comparator and several control signal generators. By comparing the feedback voltage to the reference voltage of 1.222V, the error amplifier varies the voltage at COMP pin. The voltage at COMP pin is compared with the summing signal of current sensing signal and slope compensation signal to determine the duty cycle of internal power switch.

● Current Limitation

The AIC2565 provides current limit function by using an internal sensing resistor. When the internal power switch turns on, current flows through the internal sensing resistor. And current amplifier senses the voltage, which crosses the

resistor, and amplifies it. While the sensed voltage gets higher than reference voltage, the current limitation function is activated. While the current limitation function is activated, the duty cycle will be reduced to limit the output power to protect the internal power switches.

● Short Circuit Protection

While the output is shorted to ground, the switching frequency of AIC2565 will be reduced to one third of the normal switching frequency. This lower switching frequency ensures the inductor current has more time to discharge, thereby preventing inductor current runaway. The switching frequency will automatically return to its designed value while short circuit condition is released.

● Soft-Start

The AIC2565 provides the soft-start function. Initially, the voltage at SS pin is 0V. Then an internal current source of 6μA (typ.) charges an external soft-start capacitor. During the soft-start period, the voltage at SS pin will limit the feedback threshold voltage at FB pin. When the voltage at

SS pin is higher than 1.222V, the feedback threshold voltage at FB pin reaches the desired value. The soft-start time can be calculated in accordance with the following equation.

$$t_{SS} = C_5 \times \frac{1.222V}{6\mu A}$$

The soft-start capacitor is discharged to GND when the EN pin is connected to GND.

● Shutdown

By connecting the EN pin to GND, the AIC2565 can be shut down to reduce the supply current to 22 μ A (typ.). At this operation mode, the output voltage of step-down converter is equal to 0V. For automatic startup, leave EN pin unconnected.

● Components Selection

Inductor

The inductor selection depends on the current ripple of inductor, the input voltage and the output voltage.

$$L \geq \frac{V_{OUT}}{f_S \cdot \Delta I_L} \left(1 - \frac{V_{OUT}}{V_{IN}} \right)$$

Accepting a large current ripple of inductor allows the use of a smaller inductance. However, higher current ripple of inductor can cause higher output ripple voltage and large core loss. By setting an acceptable current ripple of inductor, a suitable inductance can be obtained from above equation.

In addition, it is important to ensure the inductor saturation current exceeds the peak value of inductor current in application to prevent core saturation. The peak value of inductor current can be calculated according to the following equation.

$$I_{PEAK} = I_{OUT(max)} + \frac{V_{OUT}}{2 \times f_S \cdot L} \left(1 - \frac{V_{OUT}}{V_{IN}} \right)$$

Diode

A Schottky diode with low forward drop voltage and fast reverse recovery is the ideal choice for better efficiency. The forward drop voltage of a Schottky diode will result in the conduction losses in the diode, and the diode capacitance (C_T or C_D) will cause the switching losses. Therefore, it is necessary to consider both forward voltage drop and diode capacitance for diode selection. In addition, the rating of selected Schottky diode should be able to handle the input voltage and the maximum peak diode current.

Input Capacitor and Output Capacitor

To prevent the high input voltage ripple and noise resulted from high frequency switching, the use of low ESR ceramic capacitor for the maximum RMS current is recommended. The approximated RMS current of the input capacitor can be calculated according to the following equation.

$$I_{CINRMS} \approx \sqrt{I_{OUT(MAX)}^2 \times \frac{V_{OUT}(V_{IN} - V_{OUT})}{V_{IN}^2} + \frac{\Delta I_L^2}{12}}$$

The selection of output capacitor depends on the required output voltage ripple. The output voltage ripple can be expressed as:

$$\Delta V_{OUT} = \frac{\Delta I_L}{8 \times f_S \cdot C_{OUT}} + ESR \cdot \Delta I_L$$

For lower output voltage ripple, the use of low ESR ceramic capacitor is recommended.

When choosing the input and output ceramic capacitors, X5R and X7R types are recommended because they retain their capacitance over wider ranges of voltage and temperature than other types.

Soft-Start Capacitor

The soft-start of AIC2565 begins from $V_{SS}=0V$ and ends while V_{SS} reaches 1.222V. During the soft-start period, an internal current source of $6\mu A$ (typ.) charges the soft-start capacitor. Hence, the soft-start capacitor should be large enough to ensure that the output voltage has reached the regulation value before the soft-start function has finished.

Output Voltage Programming

By connecting a resistive divider R_1 and R_2 , the output voltage of AIC2565 step-down converter can be set. V_{OUT} can be calculated as:

$$V_{OUT} = 1.222 \times \left(1 + \frac{R_1}{R_2} \right)$$

The resistive divider should sit as close to FB pin as possible.

Loop Compensation

In order to avoid the poor output voltage ripple and low efficiency caused by instability, AIC2565 requires a proper external compensation network to compensate its feedback loop. In this external compensation network, the compensation resistor, R_3 , and the compensation capacitor, C_6 , are used to set the high-frequency integrator gain and the integrator zero. C_7 is used to cancel the zero caused by the output capacitor and its ESR. While using the ceramic capacitor as the output capacitor, C_7 can be omitted due to the small ESR.

The values of the compensation components given

in this data sheet yield a stable control loop for the given output voltage and capacitor. If different conversions and output capacitors are required, some values of the compensation components may need to be adjusted to ensure stability.

Layout Consideration

In order to ensure a proper operation of AIC2565, the following points should be managed comprehensively.

1. The input capacitor and V_{IN} should be placed as close as possible to each other to reduce the input voltage ripple and noise.
2. The output loop, which is consisted of the inductor, the internal power switch, the Schottky diode and the output capacitor, should be kept as small as possible.
3. The routes with large current should be kept short and wide.
4. Logically the large current on the converter should flow at the same direction.
5. In order to prevent the effect from noise, the IC's GND pin should be placed close to the ground of the input bypass capacitor and should be away from the ground of the Schottky diode.
6. The FB pin should be connected to the feedback resistors directly and the route should be away from the noise sources.

Fig. 16 to 19 shows the layout diagrams of AIC2565.

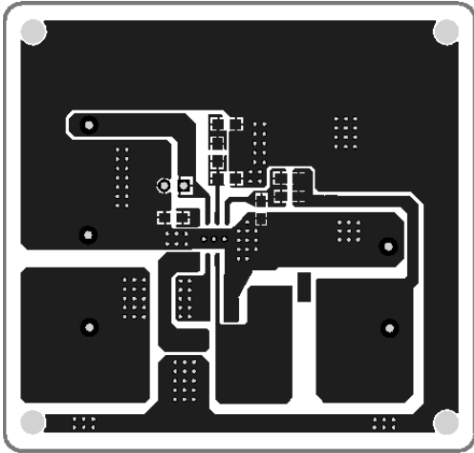

Fig. 16 Top Layer

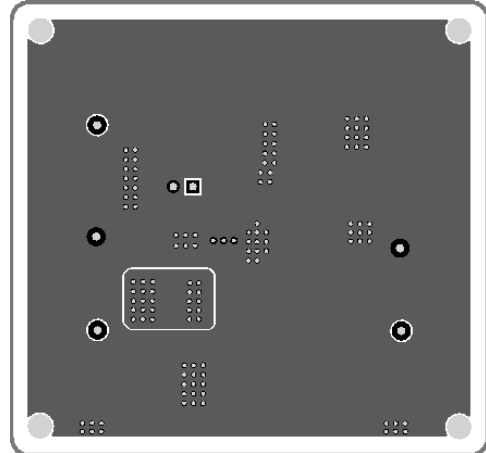

Fig. 17 Bottom Layer

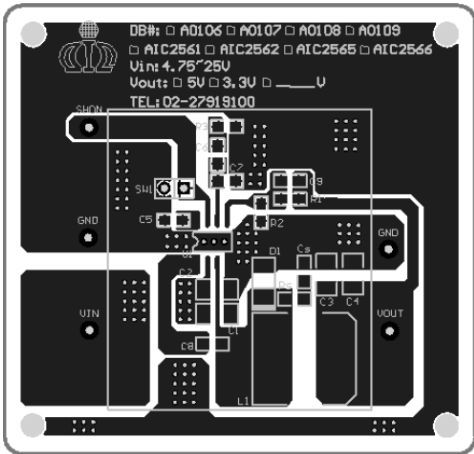

Fig. 18 Top Over Layer

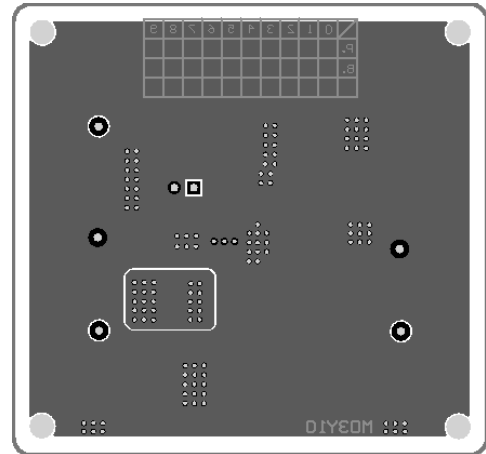
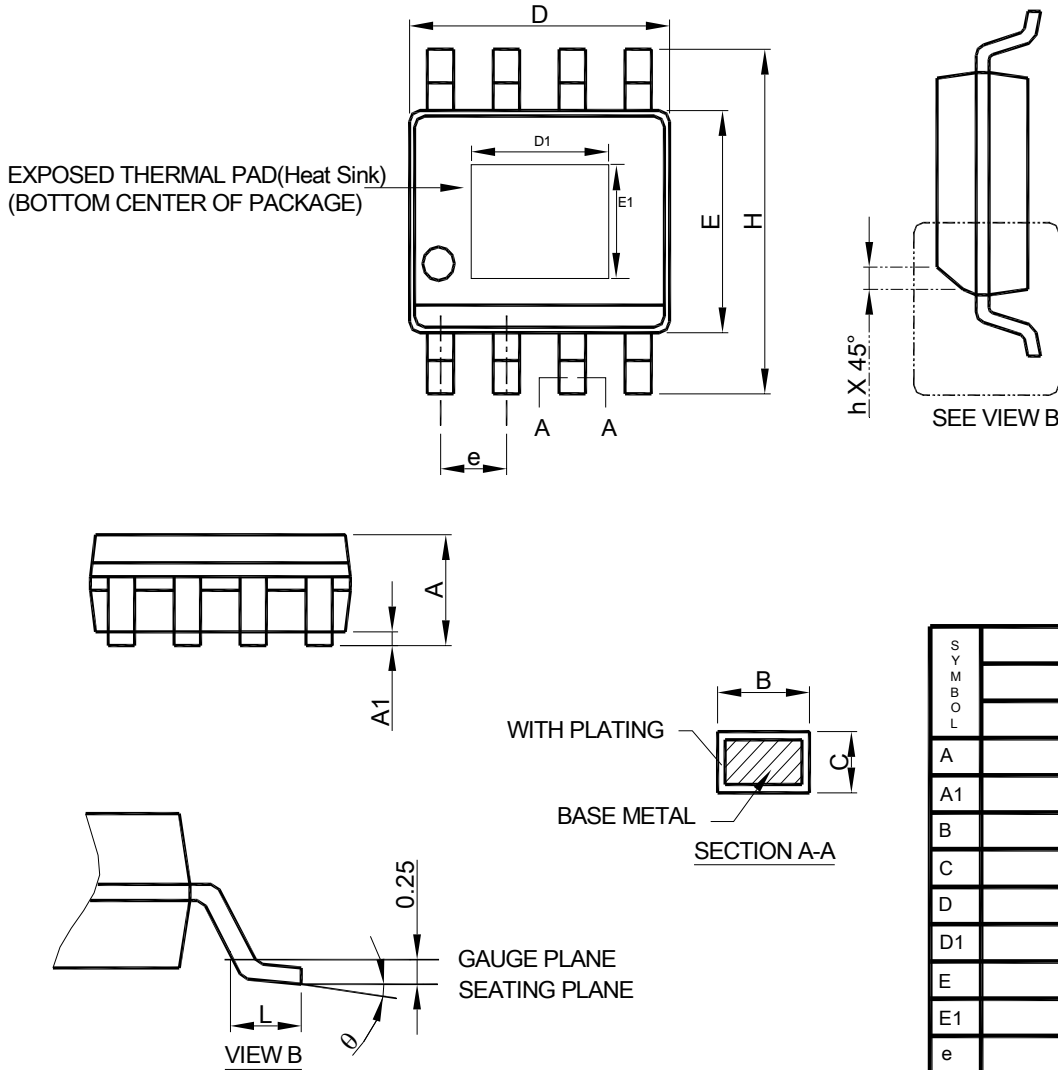

Fig. 19 Bottom Over Layer

PHYSICAL DIMENSIONS (unit: mm)

● SOP-8 Exposed Pad (Heat Sink)



SYMBOL	SOP-8 Exposed Pad(Heat Sink)	
	MILLIMETERS	
	MIN.	MAX.
A	1.35	1.75
A1	0.00	0.15
B	0.31	0.51
C	0.17	0.25
D	4.80	5.00
D1	1.50	3.50
E	3.80	4.00
E1	1.0	2.55
e	1.27 BSC	
H	5.80	6.20
h	0.25	0.50
L	0.40	1.27
θ	0°	8°

- Note :
1. Refer to JEDEC MS-012E.
 2. Dimension "D" does not include mold flash, protrusions or gate burrs. Mold flash, protrusion or gate burrs shall not exceed 6 mil per side .
 3. Dimension "E" does not include inter-lead flash or protrusions.
 4. Controlling dimension is millimeter, converted inch dimensions are not necessarily exact.

Note:

Information provided by AIC is believed to be accurate and reliable. However, we cannot assume responsibility for use of any circuitry other than circuitry entirely embodied in an AIC product; nor for any infringement of patents or other rights of third parties that may result from its use. We reserve the right to change the circuitry and specifications without notice.

Life Support Policy: AIC does not authorize any AIC product for use in life support devices and/or systems. Life support devices or systems are devices or systems which, (i) are intended for surgical implant into the body or (ii) support or sustain life, and whose failure to perform, when properly used in accordance with instructions for use provided in the labeling, can be reasonably expected to result in a significant injury to the user.